

Project Location Map
Scale: 1" = 500'

LEGEND

- BOUNDARY LINE/ R.O.W. (EXISTING)
- BOUNDARY LINE/ R.O.W. (ABUTTING)
- 100 1-FOOT LIDAR CONTOUR (OBTAINED FROM VCGI DATABASE)
- 100 1-FOOT GROUND SURVEY CONTOUR
- FINISH GRADE
- SIDELINE OF EASEMENT
- ZONING SETBACKS
- TREE LINE
- PROPOSED LIMITS OF CLEARING
- STONE WALL (EXISTING)
- DITCHLINE
- dl dl GRAVITY SEWER (EXISTING)
- S S GRAVITY SEWER (PROPOSED)
- FM FM FORCE MAIN
- W W 1-INCH DIAMETER CL200 POLYETHYLENE PLASTIC WATER LINE (UNLESS OTHERWISE NOTED)
- WELL ISOLATION
- WASTEWATER ISOLATION
- WL WL WETLAND BOUNDARY
- WB WB WETLAND BUFFER
- ue ue EXISTING UNDERGROUND ELECTRICAL CONDUIT
- UE UE UNDERGROUND ELECTRICAL CONDUIT
- GAS GAS UNDERGROUND GAS LINE
- tel tel UNDERGROUND TELEPHONE LINE
- ohw ohw UTILITY POLE/ OVERHEAD WIRES
- SURVEY TRAVERSE STATION
- TEMPORARY BENCHMARK (TYPE AND ELEVATION NOTED)
- TEST PIT (TP-01)
- DRILLED WELL (UNLESS OTHERWISE NOTED)

- PROJECT NOTES:**
- THIS IS NOT A BOUNDARY SURVEY. PROJECT PERIMETER LINES ARE BASED ON A PLAN ENTITLED 'LANDS OF BADLEY JAY LAROSE & KAREN C. LAROSE, 156 WORTHHEIM ROAD, RICHMOND, VERMONT, TWO-LOT SUBDIVISION SURVEY PLAT' BY BARNARD & GERVAIS, LLC, DATED 03/15/2023.
 - THE LOCATIONS OF EXISTING PHYSICAL FEATURES ON THIS PLAN ARE BASED ON A TOPOGRAPHIC SURVEY COMPLETED BY BARNARD AND GERVAIS, LLC IN NOVEMBER 2022.
 - THE ELEVATIONS ON THIS PLAN WITHIN THE DASHED BOUNDARIES SHOWN ARE 1-FOOT CONTOURS BASED ON NAVD83 (GEOID12B) ESTABLISHED FROM SURVEY GRADE GNSS READINGS COLLECTED WITH A TOPCON HIPER SR GNSS RECEIVER ADJUSTED TO VERMONT GRID ON RANDOM CONTROL POINTS USING REAL TIME KINEMATIC CORRECTIONS FROM A VIRTUAL REFERENCE STATION OF THE VT CORS NETWORK. THE ELEVATIONS ON THIS PLAN OUTSIDE THE DASHED BOUNDARIES SHOWN ARE 1-FOOT LIDAR CONTOURS OBTAINED FROM THE STATE OF VERMONT VCGI OPEN DATA PORTAL DATABASE.
 - FOR CLARITY, TEXT IDENTIFYING EXISTING ITEMS IS LOWER CASE; TEXT IDENTIFYING PROPOSED ITEMS IS UPPER CASE.
 - NO ATTEMPT HAS BEEN MADE TO LOCATE ANY UNDERGROUND UTILITIES BY BARNARD AND GERVAIS, LLC. THE CONTRACTOR WILL BE RESPONSIBLE FOR CONTACTING DIG SAFE TO HAVE ANY UNDERGROUND UTILITIES MARKED PRIOR TO ANY EXCAVATION OR SITE WORK. THE CONTRACTOR SHALL NOTIFY THE DIG SAFE NETWORK AT LEAST 72 HOURS PRIOR TO THE START OF CONSTRUCTION.
 - THIS WASTEWATER DISPOSAL SYSTEM HAS BEEN DESIGNED IN ACCORDANCE WITH THE STATE OF VERMONT, AGENCY OF NATURAL RESOURCES, ENVIRONMENTAL PROTECTION RULES, CHAPTER 1, "WASTEWATER SYSTEM AND POTABLE WATER SUPPLY RULES" EFFECTIVE APRIL 12, 2019.
 - NO WETLANDS WERE SHOWN ON THE SUBJECT PARCEL ON THE "VERMONT NATURAL RESOURCES ATLAS" AND NO OTHER WETLAND DELINEATION OF SAID PARCEL HAD BEEN CONDUCTED OF WHICH BARNARD & GERVAIS, LLC IS AWARE. BARNARD & GERVAIS, LLC MAKES NO WARRANTIES THAT WETLANDS OR ASSOCIATED BUFFERS DO OR DO NOT EXIST ON SAID PARCEL. IT IS RECOMMENDED THAT THE LANDOWNER OR CONTRACTOR CONTACT A WETLAND SPECIALIST TO CONFIRM NO WETLANDS EXIST PRIOR TO ANY EARTH WORK OR CONSTRUCTION. BARNARD & GERVAIS, LLC DOES HAVE A WETLAND SPECIALIST ON STAFF.
 - BARNARD & GERVAIS, LLC IS NOT RESPONSIBLE FOR ANY ASPECTS OF HEALTH AND SAFETY ASSOCIATED WITH THIS PROJECT.
 - ALL EXCAVATION WORK SHALL BE PERFORMED IN ACCORDANCE WITH APPLICABLE STATE OF VERMONT, OCCUPATIONAL SAFETY AND HEALTH ADMINISTRATION (OSHA) GUIDELINES FOR TRENCH EXCAVATIONS.
 - THE CONTRACTOR AND/OR LANDOWNER SHALL ADHERE TO THE GUIDELINES SET FORTH IN THE STATE OF VERMONT EROSION AND SEDIMENT CONTROL HANDBOOK FOR CONSTRUCTION SITES. IT IS THE RESPONSIBILITY OF THE LANDOWNER OR SITE CONTRACTOR TO ENSURE THESE GUIDELINES ARE FOLLOWED AND EROSION/SEDIMENT CONTROL MEASURES ARE MAINTAINED THROUGHOUT THE COURSE OF THE PROJECT.
 - THE REPLACEMENT MOUND WASTEWATER DISPOSAL SYSTEM FOR LOT 1 SHALL NOT BE CONSTRUCTED UNTIL THE DESIGN IS COMPLETED BY A LICENSED DESIGNER OR PROFESSIONAL ENGINEER AND A PERMIT AMENDMENT IS SUBMITTED TO THE MONTPELIER REGIONAL OFFICE OF THE DEPARTMENT OF ENVIRONMENTAL CONSERVATION.
 - AS SHOWN, THE PROJECT CONTAINS 13,780 SF OF IMPERVIOUS SURFACE AREA.

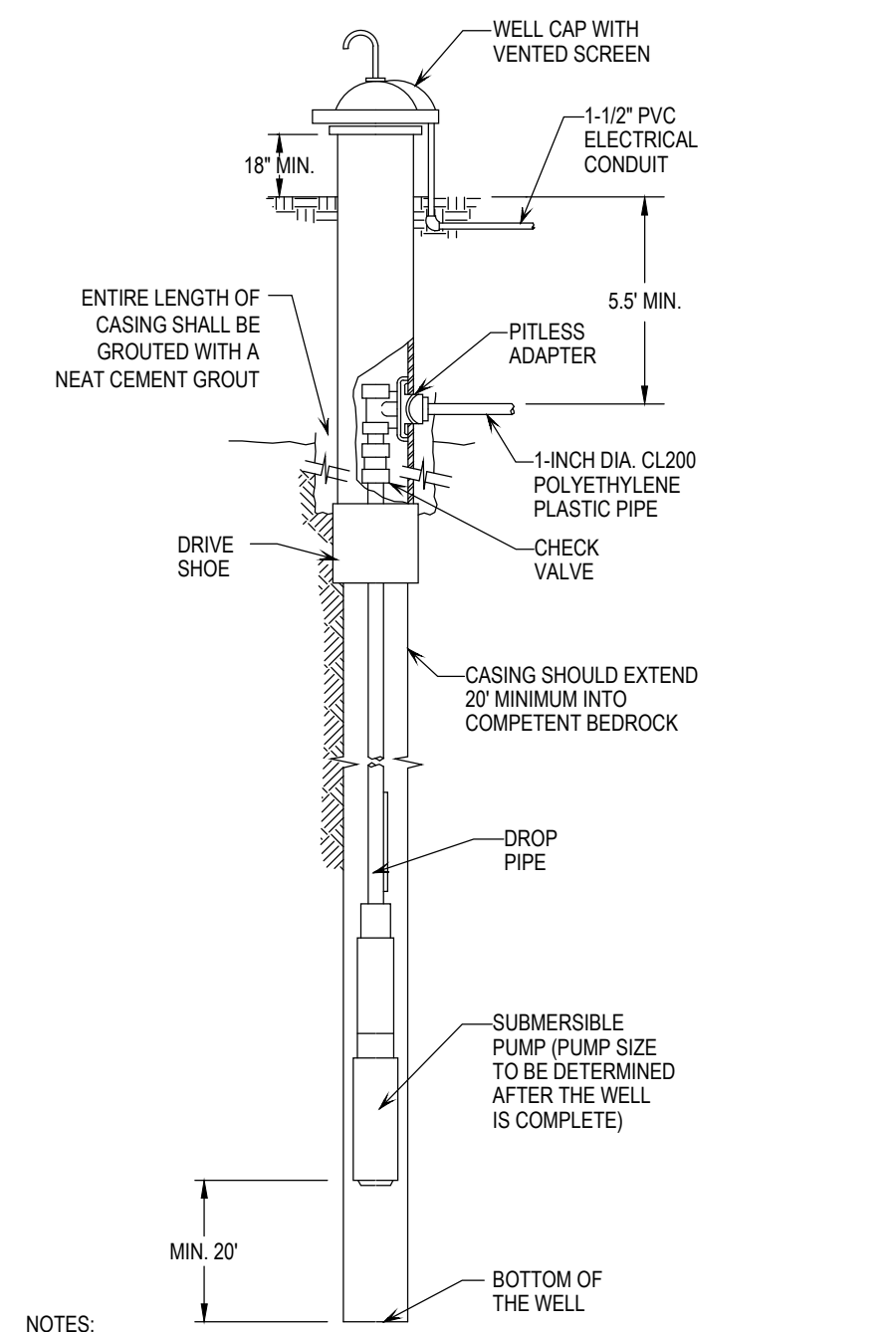
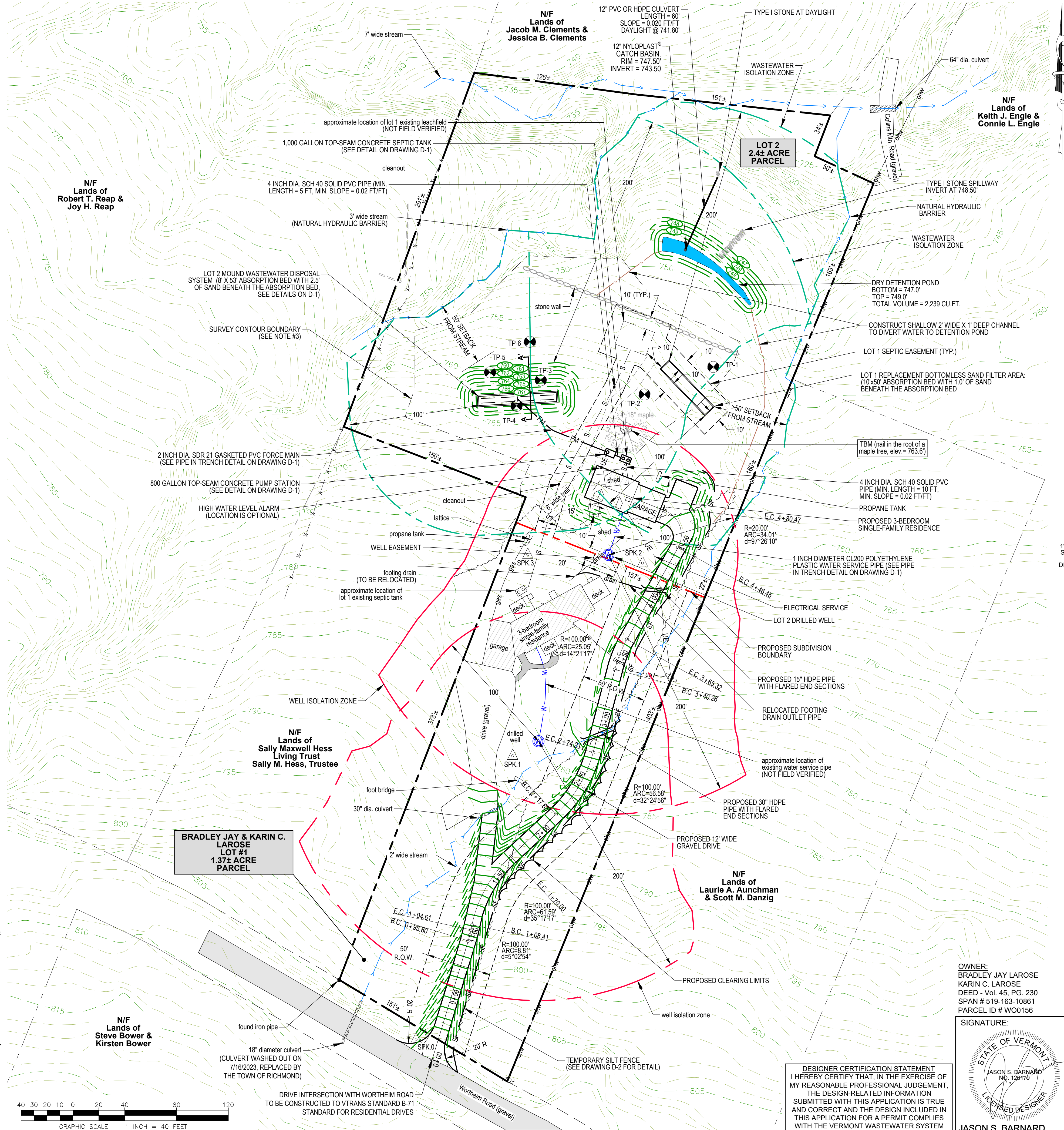

NOTES:

- THE DRILLED WELL SHALL BE CONSTRUCTED IN ACCORDANCE WITH §1-1206 OF THE STATE OF VERMONT ENVIRONMENTAL PROTECTION RULES, CHAPTER 1, EFFECTIVE APRIL 12, 2019.
- THE DRILLED WELL LOCATION SHALL ADHERE TO THE ISOLATION DISTANCES SHOWN ON THE DRILLED WELL ISOLATION TABLE ON THIS DRAWING.

DRILLED WELL CONSTRUCTION DETAIL
NOT TO SCALE

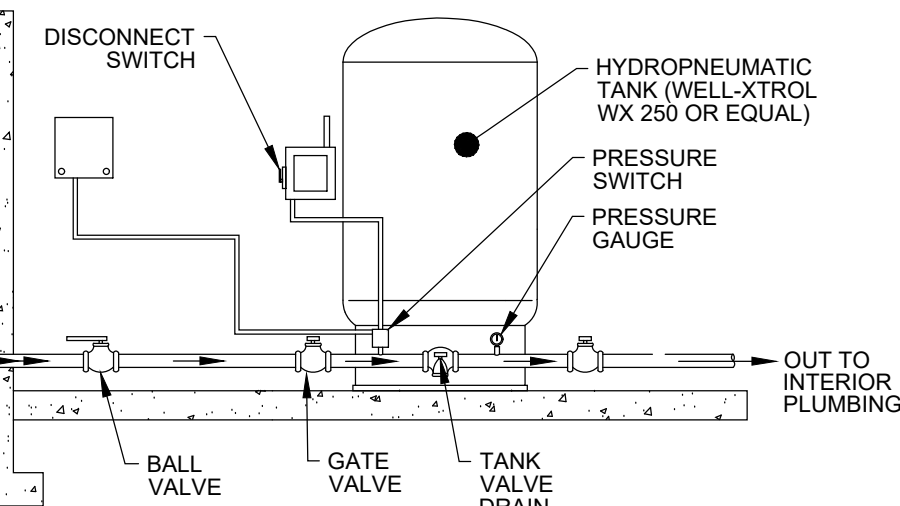

NOTES:

- HYDROPNEUMATIC TANK (TO BE DETERMINED).
- PRESSURE SWITCH SETTING 40-60 PSI.
- ALL INTERIOR PLUMBING AND WATER DISTRIBUTION DESIGN TO BE PERFORMED ACCORDING TO APPLICABLE PLUMBING CODE BY A LICENSED PROFESSIONAL.

SCHMATIC ONLY
TYPICAL COMPONENTS FOR A DRILLED WELL SUBMERSIBLE WELL PUMP WATER SYSTEM
ELEVATION VIEW - NOT TO SCALE

DATE	DESCRIPTION	RW	BY
08/28/2023	ADDED PROPANE TANK & LINE TO PROPOSED HOME ON LOT 2		RW

REVISIONS	
	BARNARD & GERVAIS, LLC Land Surveying Water & Wastewater Environmental Consulting 167 Main Street, P.O. Box 820 Enosburg Falls, VT 05450 Telephone: (802) 933-5168
PROJECT NO.	22356
DATE:	03-23-2023
SCALE:	1" = 40'
SURVEY:	AW, SR
DRAWN:	CS
CHECKED:	JB
DRAWING NO.	S-1
SHEET 1 OF 3	

OWNER:
BRADLEY JAY LAROSE
KARIN C. LAROSE
DEED - Vol. 45, PG. 230
SPAN # 519-163-10861
PARCEL ID # W00156

SIGNATURE:

JASON S. BARNARD
LICENSED DESIGNER #126179

DESIGNER CERTIFICATION STATEMENT
I HEREBY CERTIFY THAT, IN THE EXERCISE OF MY REASONABLE PROFESSIONAL JUDGEMENT, THE DESIGN-RELATED INFORMATION SUBMITTED WITH THIS APPLICATION IS TRUE AND CORRECT AND THE DESIGN INCLUDED IN THIS APPLICATION FOR A PERMIT COMPLIES WITH THE VERMONT WASTEWATER SYSTEM AND POTABLE WATER SUPPLY RULES.

