

May 17, 2023

Tyler Machia  
Zoning Administrative Officer  
Town of Richmond  
203 Bridge Street  
Richmond, VT 05477

RE: 22 Depot Street Mixed Use Addition – Final Subdivision Application

Dear Tyler,

Please find attached a Final Subdivision application for the mixed use addition project at 22 Depot Street. The applicant, Jameson Partners LLC is proposing an addition to the west side of the existing structure to include two commercial or retail spaces on the lowest level and 4 new residential dwellings on the second and third floors. A new 12 space formalized parking lot with landscaping, stormwater treatment, and lighting will be constructed at the rear of the building.

We have attached 3 full size plan sets and 8 reduced (11"x17") plan sets with the supporting application material. We have coordinated the design with the Water & Sewer Commission, the Town Manager, the Highway Foreman, and the town's engineer and received approvals and endorsements. We have sent plans to the Fire Chief and are awaiting any final review comments.

Button Land Surveyors is currently working on the Final Plat. They were the survey firm who completed the boundary survey for the Richmond Block in 2000, which includes this parcel. The plan will include all the required elements for both Preliminary and Final Plat. Most of this information is already provided on the Overall Site Plan but we recognize a plan must be submitted that is signed by a Licensed Land Surveyor. While the plat may be ready in time for our DRB hearing, in the event that it's not, we are requesting the project be reviewed with a condition that the plat be prepared to your satisfaction.

Finally, as part of the subdivision checklist requirements, please consider this letter confirmation that to the best of our knowledge the public and private infrastructure has been designed in conformance with the Richmond Subdivision Regulations and other standards established by the Town of Richmond such as Zoning Regulations and Public Works Specifications.

Please contact us if you have any questions or comments regarding this application.

Sincerely,



Derick M. Read, P.E.

Enclosure





# FINAL SUBDIVISION APPLICATION

Permit # \_\_\_\_\_

Parcel ID: \_\_\_\_\_

Please review the Richmond Zoning & Subdivision Regulations and provide all the information requested in this application. For information contact the Zoning Administrative Officer at 802-434-2430. Other federal, state and local permits or approvals may additionally be required, it is the duty of the applicant to obtain all relevant and applicable approvals. To inquire about State permits contact the State Permit Specialist at 802-477-2241.

Application Date: 4/28/2023 Physical Address of Property: 22 Depot Street

Total acreage of Subdivision: 0.27 acres Subdivision Name: 22 Depot Street Mixed Use Addition

Number of lots: New 0 Existing 1 Total lots 1

Advisor Name (if applicable): Derick Read, Krebs & Lansing Property Owner Name: Jameson Partners LLC

Advisor Mailing Address: 164 Main Street  
Colchester, VT 05446 Owner Mailing Address: 734 Pitt Street  
Mount Pleasant, SC 29464

Phone: (802) 878-0375

Phone: (802) 522-5959

Email: derick.read@krebssandlansing.com

Email: nicholasmdonahue@gmail.com

**The final subdivision plat shall be consistent in all respects to the layout as approved by the DRB for Preliminary Subdivision. The final plat shall be drawn to a scale of not more than two-hundred (200) feet to the inch, and shall show:**

- SUBDIVISION name or identifying title, the name of the municipality, the name and address of the owner of record of the property, and of the SUBDIVIDER (if different), the name, registration number and seal of the registered land surveyor, the boundaries of the SUBDIVISION and its general location in relation to existing roads or other landmarks, scale, date, magnetic north, with true north declination and legend;
- Road names and lines, pedestrian ways, recreational trails, LOTS, reservations, easements and areas to be dedicated to public use, if any;
- The location, bearing length of every road line, LOT line and boundary line. All locations should be tied to known reference points such as road intersections;
- The length of all straight lines, the deflection angles, radii, length of curves, tangent distances and bearings for each road;
- All public open space for which offers of dedication are made by the SUBDIVIDER, and those spaces for which title is reserved by the SUBDIVIDER;
- LOTS within the SUBDIVISION numbered sequentially (any reserved land shall have the highest number). Below each LOT number, with the LOT boundaries, the following shall be listed: the acreage, new parcel ID number, and building envelope to contain all proposed primary structures.
- The location of any zoning overlay district(s) applicable to the proposed SUBDIVISION;
- Location of well shields on all LOTS;
- Location of all improvements referred to in ARTICLE VI, landscaping, utility poles, and rough grading and other devices for draining the area within the SUBDIVISION;
- Locations of proposed MONUMENTS at all right-of-way intersections and at all points of curvature (P.C) and points of tangency (PT) on both sides of any road lines, and at any other critical points in the road lines as will enable a land surveyor to correctly stake out any LOT in the SUBDIVISION;
- Names of all SUBDIVISIONS immediately adjacent and the names of ADJOINING PROPERTY OWNERS; and
- SUBDIVISION location map.

Along with the FINAL SUBDIVISION **PLAT**, the SUBDIVIDER shall submit to the Town a set of materials that constitute a FINAL SUBDIVISION **PLAN**, which shall include the following information:

- Location and envelope area of wastewater disposal system(s) including primary and any required replacement areas, and a letter from the wastewater disposal system designer stating that all such systems will be designed and constructed in conformance with all applicable state regulations and standards;
- For lots that require a State Wastewater or Subdivision permit, a copy of any permit for on-site sewage systems from the Vermont Agency of Natural Resources;
- Location of and envelope area of all existing and proposed sources of potable water and wastewater system(s);
- Location and design of all of the considerations and improvements referred to in Article V (Planning Standards) and Article VI (Required Improvements and Design Standards);
- Identification and methods of protection of natural features or site elements (i.e., streams, ponds, wetlands, flood plain, forest stands, established LARGE ANIMAL HABITAT, rock outcroppings, etc.);
- Typical cross sections and proposed grading of roadways;
- Designs of any bridges or culverts which may be required on the SUBDIVISION;
- A signed statement reciting:
  - A) the location, type and length of any proposed road or roads. All roads shall be designed to the specification in SECTION 600 of these Subdivision Regulations;
  - B) the nature and extent of any recreational features, open spaces, parks, or playgrounds to be provided, if any, and intended to be dedicated to the Town.
- Contour of finish grades at five (5) foot intervals if finished grade varies from existing grade by five (5) feet or more, except that contours at two (2) foot intervals shall be shown in areas where wastewater disposal systems are to be located;
- At the discretion of the DRB, letters from the Chittenden East School District Superintendent, the Richmond Police Chief, the head of Richmond Rescue, and the Richmond Fire Chief indication their assessment of the impact of the proposed SUBDIVISION on the provision of school, police, rescue or fire protection services, or letters from others on relevant issues;
- Any other documents required by the DRB as a result of SKETCH PLAN, PRELIMINARY SUBDIVISION OR FINAL SUBDIVISION ;

**Submittal Materials:**

- Three** copies of a complete Final Subdivision Application that includes: One 24"x36" and three reduced (11"x17") prints of plat and plan.
- Submit fee based on the Richmond Fee Schedule and made payable to the Town of Richmond.
- The Subdivider shall submit one set of stamped envelopes addressed to all owners of contiguous property, including properties directly across any road or right-of-way from the proposed subdivision.

I hereby give my assurance that the above information is complete, accurate, and included in this submittal.

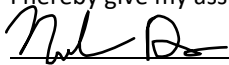

Signed by Landowner or agent (a letter of authorization must accompany submittal if agent signs)

Date **5/1/23**

— DO NOT WRITE BELOW THIS LINE—OFFICE USE ONLY—DO NOT WRITE BELOW THIS LINE—OFFICE USE ONLY—DO NOT WRITE BELOW THIS LINE—OFFICE USE ONLY —

Notices sent to adjoining landowners (date): \_\_\_\_\_ DRB Hearing Date: \_\_\_\_\_

Comments: \_\_\_\_\_ Zoning Fee: \_\_\_\_\_

Zoning Administrative Officer signature: \_\_\_\_\_ Date: \_\_\_\_\_



Planning & Zoning Office  
 Town of Richmond P.O. Box 285  
 Richmond, VT 05477  
 (802) 434-2430  
 tmachia@richmondvt.gov  
 www.richmondvt.gov

**Final Subdivision Checklist:**

**This checklist is intended to help you provide the necessary information for your Final Subdivision Review. Please ensure that you submit all of the information listed below. This list is meant to be a guide. Please consult the Richmond Zoning regulations for a complete list of regulations. If you have any questions, please contact the Richmond Zoning Department.**

<b>Final Subdivision Plat Information</b>	
<b>Requirement</b>	<b>Check the Box if this information is included on your Plat</b>
All of the information required for a Preliminary Subdivision plat	<b>X - provided on Overall Site Plan. Final Plat forthcoming</b>
Subdivision name or identifying title	<b>X</b>
Name of the municipality	<b>X</b>
Name and address of the owner of record	<b>X</b>
Name of the Subdivider if different from owner of record	<b>N/A</b>
Scale shall be 1 inch equals 200 feet	<b>X</b>
True North declination and Legend	<b>X</b>
Length of all straight lines, deflection angles, radii, length of curves, tangent distances and bearing of each road	<b>No new road proposed</b>
All public open spaces for which an offer of dedication has been made	<b>N/A</b>
Lots within the subdivision require sequential numbering (any remaining land must be given the higher number)	<b>No new lots are being created</b>
Lots listed on plat need to note lot number, acreage, and parcel ID number	<b>X</b>
Building envelope containing all proposed structures	<b>X The 5 ft setback is shown on the plans</b>
Location of easements on all lots (if applicable)	<b>A Final Plat will be forthcoming</b>
Location of proposed monuments at all right of way intersections both sides of any road lines	<b>No new monuments proposed</b>
Names of property owners adjacent to the proposed subdivision	<b>X</b>

Subdivision location map using a USGS map	<b>X</b>
The name, location and widths of existing roads	<b>X</b>

<b>Supporting Plan Set</b>	
<b>Requirements</b>	<b>Check the Box if this information is included on your plan set</b>
Location and envelope area of wastewater disposal system	<b>Municipal water and sewer</b>
Location and envelope of replacement wastewater disposal system.	<b>Municipal water and sewer</b>
Location of envelope area for proposed sources off potable water	<b>Municipal water and sewer</b>
Locations of bridges, drains, drainage ways or culverts	<b>X</b>
Location of building setbacks	<b>X</b>
Name of subdivider (if different)	<b>N/A</b>
Proposed lot lines with dimensions	<b>No new lot lines proposed</b>
Planned location of buildings	<b>X</b>
Stream and wetland buffer zones (if applicable)	<b>N/A</b>
Overlay district applicable to the subdivision	<b>N/A</b>
Layout of subdivision showing roads pedestrian rights of way and recreational trails	<b>None proposed</b>
Identification and methods of protection of natural features or site elements (i.e., streams, ponds, wetlands, flood plain, forest stands, established large animal habitat, rock outcroppings, etc. If applicable)	<b>None present</b>
Typical cross sections and proposed grading of roadways	<b>X</b>
Designs of any bridges or culverts which may be required on the subdivision	<b>N/A</b>

<b>Supporting Documents</b>	
<b>Requirements</b>	<b>Check the Box if this information is included in your supporting documentation</b>
Final Subdivision Application	<b>X</b>
Narrative	<b>X</b>
Letter from wastewater system engineer	<b>An email from Tyler Billingsley is attached</b>
Overlay district the property is located in (if applicable)	<b>Not Applicable</b>
Wastewater/ water plan	<b>X</b>
Utilities plan	<b>X</b>
A signed statement reciting the location, type and length of any proposed road or roads. All roads shall be designed to the specifications in SECTION 600 of the Subdivision Regulations	<b>X</b>
A signed statement reciting the nature and extent of any recreational features, open spaces, parks, or playgrounds to be provided, if any, and whether or not and under what conditions they are intended to be dedicated to the Town	<b>None proposed</b>
A letter from a professional engineer retained by the subdivider stating that all proposed public and private infrastructure is in compliance with these Subdivision Regulations and other standards established by the Town of Richmond such as Zoning Regulations, Public Works Specifications or other standards	<b>X</b>
3 full size 24 x36 plans	<b>X</b>
8 copies 11 x17 of subdivision application, final subdivision plat, final subdivision plan, supporting documentation listed above,	<b>X</b>







Planning & Zoning Office  
 Town of Richmond P.O. Box 285  
 Richmond, VT 05477  
 (802) 434-2430  
 tmachia@richmondvt.gov  
 www.richmondvt.gov

**Preliminary Subdivision Checklist:**

**This checklist is intended to help you provide the necessary information for your Preliminary Subdivision Review. Please ensure that you submit all of the information listed below. This list is meant to be a guide. Please consult the Richmond Zoning regulations for a complete list of regulations. If you have any questions, please contact the Richmond Zoning Department.**

<b>Preliminary Subdivision Plat Information</b>	
<b>Requirement</b>	<b>Check the Box if this information is included on your Plat</b>
Subdivision name or Title	<b>X</b>
Tax map Number	<b>X</b>
Name of the Town	<b>X</b>
Name and address of owner or record of the property	<b>X</b>
Name and address of subdivider (if different from the owner of record )	<b>Same as owner</b>
A location map showing the relationship of the proposed subdivision to adjacent properties and surrounding area within 2000 feet of any property line	<b>X</b>
Location map should be a USGS map at scale of 1inch equals 2,000 feet	<b>X</b>
Boundaries of the proposed Subdivision	<b>X</b>
Names of the owners of record of all the surrounding properties to the proposed subdivision	<b>X</b>
Existing easements within proposed subdivision (if applicable)	<b>This will be provided with Final Plat, if easements exist</b>
Date prepared	<b>X</b>
True North arrow and scale	<b>X</b>
Name of the municipality	<b>X</b>
Name, registration number, and seal of the registered land surveyor	<b>This will be provided with Final Plat</b>

<b>Preliminary Subdivision Plan</b>	
<b>Requirements</b>	<b>Check the Box if this information is included on the Plan</b>
Name of the designer of the subdivision	<b>See individual plans</b>
Number of acres within the proposed subdivision	<b>X</b>
Location of natural features (streams, ponds, wetlands large animal habitat etc.)	<b>N/A</b>
Designation of each segment of adjoining property boundaries for all adjoining properties	<b>X</b>
The location of known archeological sites (old cellar holes, foundations, wells, old stone fences Etc.)	<b>None</b>
Location and dimensions of existing wastewater disposal system	<b>N/A</b>
Location and dimensions of existing water supplies	<b>X</b>
Location and dimensions of existing culverts, drains and drainage ways	<b>New stormwater treatment system shown</b>
Location name and widths of parks, public open spaces, trails	<b>N/A</b>
Location name and widths of parks, public open spaces and trails on adjacent properties	<b>N/A</b>
Contour lines at intervals of 20 feet of existing grades	<b>X</b>
Proposals for maintaining open spaces, natural features and resources on the site	<b>N/A</b>
Master Development Plan Per section 610.1	<b>X</b>
Conceptually show future roads	<b>N/A</b>
Conceptually show future stormwater infrastructure	<b>N/A</b>
Conceptually show future building areas	<b>N/A</b>
Conceptually show future open areas ( if applicable)	<b>N/A</b>
Conceptually show future uses	<b>N/A</b>
Storm water plan	<b>X</b>
Landscape plan	<b>X</b>

<b>Supporting Documents</b>	
<b>Requirements</b>	<b>Check the Box if this information is included in Supporting Documentation</b>
Preliminary Subdivision Application form	
Narrative	<b>X</b>
Overlay district the property is located in (if applicable)	<b>N/A</b>
Letters of support (if applicable)	<b>X</b>
Draft legals	<b>N/A</b>
ANR atlas maps for wildlife habitat/ suspected wetlands (if applicable)	<b>N/A</b>
Signed statements (if applicable)	<b>N/A</b>
HOA documents (if applicable)	<b>N/A</b>
Building elevations	<b>X</b>

22 Depot Street  
Zoning Permit Narrative  
Final Plat Application

PROJECT DESCRIPTION:

Jameson Partners, LLC, is proposing a mixed-use addition to the existing historic structure at 22 Depot Street (Now or Formerly Giffords Mortuary.) Site re-development would entail removal of several single-story wood frames garages and storage buildings, consolidation and reconstruction of onsite parking, and construction of a three-story addition with commercial lease space on the ground floor, and four apartments above. The project Site is in the Village Downtown District.

- Lot Area: 11,898 s.f.
- Building Coverage: 4675 s.f.
- Total Coverage 80%
- Allowable lot coverage 80%
- Building Height: 35 feet maximum
- Village Downtown District (VD)
  - Density requirements for VD district
    - Each residential dwelling unit shall require 1/24 acre of developable land located on the same lot as the unit subject to the rounding rule below. This equals a residential density of approximately 24 units per acre. Developable land excludes those lands that are outlined in section 2.5.2. The maximum number of units that may be permitted shall be calculated by multiplying the residential density by the total developable acreage of the lot. When this calculation results in a number of units with a fractional component, the fraction will be rounded according to conventional rounding rules. **Per this calculation 6 residential units are allowed. With the addition of 4 new units proposed development would not exceed 6 residential units**
  - Setback:
    - b) Setback- All structures shall have zero (0) feet setbacks, except for a five (5) feet setback for all structures on district boundaries. All development is required to install and maintain a sidewalk to the public works standards on any and all public road frontage. Placement of the sidewalk and curb cuts or accesses to the property are subject to approval of the Highway Foreman. **A 5 foot setback has been provided on the west side of the property as that portion of site borders a separate zoning district.**
  - Parking Requirements
    - In this district, the residential parking requirement shall be based on the number of bedrooms per dwelling unit. The spaces required shall only serve to calculate overall supply and shall not be assigned to specific dwellings. **There are six two-bedroom apartments requiring 12 parking spaces. The spaces are provided at the rear of the building. The project is seeking a waiver for the parking requirements for the mixed-use space as the business hours will be staggered and there are additional parking space located nearby. The parking lot is located behind the building to provide adequate screening from the public right of way.**

## **Final Plat Requirements**

- A Final Plat is being prepared for the property that will include the required elements for the preliminary and final subdivision plat. We recognize that this plan is required and request that the project be approved with condition that the plat be prepared to the satisfaction of the Zoning Administrator.

## **Section 4 Standards**

- Compliance with Public Works Specifications
  - The plan set has been forwarded to the Town Manager and the Water Resources Department.
- Required Frontage
  - The project includes development on an existing lot with existing frontage on Depot Street.
- Curb cuts
  - The project is served by a single curb cut that exists on the east side of the existing building. A second curb cut exists on the lot but will be eliminated with the construction of the new addition.
- Multiple Use of Lots
  - The new addition will be attached to the existing building so there will only be one principal structure on the lot. The project is proposing to continue the current use of the lot. Commercial and retail space will be used on the lowest level and residential space on the upper floors.
- Nonconforming Lot and Nonconforming Structures
  - This regulation is not applicable to this development. The lot and structure is and will continue to be conforming.
- Nonconforming Uses
  - The project is proposing to operate as a conforming use for the commercial/retail space on the lower floor and residential use on the upper floors.
- Noise
  - The Commercial and Residential Noise regulations will be followed.
- Exterior Lighting
  - The parking lot lighting has been designed to provide the minimum lighting necessary to ensure adequate vision and comfort in parking areas, and to not cause glare or direct illumination on adjacent properties or Roads or Highways. Two new 12 foot high downshielded LED light poles will be installed to illuminate the parking lot. A photometric plan is included showing illumination levels remaining on the parcel and within the required levels outlined in the Richmond Zoning Regulations
  - No illuminated signs or building facades are proposed.
- Height of Buildings and Structures
  - The building height will not exceed 35 feet.
- Performance Standards
  - The performance standards outlined in section 4.12 (a through h) will be met.

## **Section 6 Standards**

- Section 6.1 Parking and Loading
  - Loading Requirements – No loading facilities are proposed.
  - Parking Requirements - There are six two-bedroom apartments requiring 12 parking spaces. The spaces are provided at the rear of the building. The project is seeking a waiver for the parking requirements for the mixed-use space as the business hours will be staggered and there are additional parking spaces located nearby. The

parking lot is located behind the building to provide adequate screening from the public right of way.

- A waiver from the 25 ft wide aisle is requested. We are proposing a 22-foot wide aisle which we feel is adequate for vehicle backing and maneuvering.
  
- Section 6.1.6 Other Parking Standards and Applicability
  - Location: The parking lot will be located at the rear of the building.
  - Surfacing: The parking lot will be paved
  - Drainage: An underground infiltration chamber system has been designed under the parking lot behind the building. A stormwater narrative with supporting calculations and plans is included with this application to show that the post development peak discharge rate does not exceed the predevelopment conditions.
  - f) Setbacks: A 5 foot setback has been provided on the west side of the property as that portion of site borders a separate zoning district.
  - g) Screening: The parking lot is located at the rear of the building to be screened from the public right of way.
  - h) Landscaping: There is limited land available around the site for landscaping but three deciduous trees have been designed around the parking lot.
  - i) Pedestrian Access: The parking lot is small and does not have an outlet so potential hazards for pedestrian conflict with vehicles is minimal.
  - j) Bicycle Access: The parking lot has less than 15 spaces so bicycle racks are not required.
  - k) Striping: The parking stripe pavement markings will be installed as part of the project.
  - l) Traffic control signs: None proposed
  - m) Lighting: The parking lot lighting has been designed to provide the minimum lighting necessary to ensure adequate vision and comfort in parking areas, and to not cause glare or direct illumination on adjacent properties or Roads or Highways. Two new 12 foot high downshielded LED light poles will be installed to illuminate the parking lot. A photometric plan is included showing illumination levels remaining on the parcel and within the required levels outlined in the Richmond Zoning Regulations
  - p) Waivers: The project is seeking a waiver for the parking requirements for the mixed-use space as the business hours will be staggered and there are additional parking spaces located nearby.
  
- Section 6.2 Driveway
  - The existing shared driveway will continue to be used and will retain its existing 9 foot width. The driveway grade does not exceed 12%. We are requesting a waiver from the 12' wide driveway width to maintain the existing 9 foot width.
  
- Traffic Impact
  - The 6 apartments and new commercial space will not create an undue adverse impact to overall traffic or peak am/pm conditions.
  - The existing curb cut on the property will be maintained. No additional curb cuts have been proposed.
  
- Landscaping
  - A Landscape Plan (Sheet L-1) is included with this application to show the trees and shrubs that are proposed for the site. The project cost exceeds \$500,000 so 1% of the construction cost must be allocated to landscaping. The landscape requirement for this project is estimated to be \$19,500. To meet that the landscape design includes:

- (50) Green mountain Boxwoods in a #10 container with a wholesale plant cost totaling \$ 9,199.50
    - Three Acer Rubrum “Boxhall” red maples with a wholesale plant cost of \$244.95 each or \$734.85 total
  - The total cost of plants is multiplied by 2.5 to provide planting labor, soils prep and warranty adds up to **\$24,835.86** which exceeds the minimum requirement
- Drainage and Fill
  - Stormwater – An underground infiltration chamber system has been designed under the parking lot behind the building. A stormwater narrative with supporting calculations and plans is included with this application to show that the post development peak discharge rate does not exceed the predevelopment conditions.
  - Erosion Control – An erosion control design is provided on attached plan sheet C-3.0. The plan include perimeter sediment control measures, inlet protection, a stabilized construction entrance, and stabilization requirements during and after construction.
- Water & Sewer
  - The existing building sewer service will be used to collect and convey wastewater flows from the new building. A new 4” water service will be needed to provide domestic supply and fire protection for the new addition. The project received preliminary allocation from the Water & Sewer Commission on March 13, 2023. The project has been reviewed by the Town’s Water Resource Superintendent, Allen Carpenter and the Tyler Billingsley.
- Master Development Plan
  - A Master Development Plan has been included with the application. Refer to plan sheet C-5.0
- Additional Options for Storage
  - A new 10’x12’ shed will be provided at the back of the site for trash/recycling bin and other tenant uses. The shed size has been maximized to the extent that maintains the lot coverage for the parcel.

## Introduction and Overview:

On behalf of Jameson Partners, LLC, we propose a mixed-use addition to the existing historic structure at 22 Depot Street (Now or Formerly Giffords Mortuary.) Site re-development would entail removal of several single-story wood frames garages and storage buildings, consolidation and reconstruction of onsite parking, and construction of a three-story addition with commercial lease space on the ground floor, and four apartments above.

The project Site is in the Village Downtown District. Mixed use projects in this district are treated as conditional uses. Such conditional mixed uses are reviewed as planned unit developments, and are further reviewed as sub-divisions.

The lot area is .27 acres. The existing Mortuary will remain as approved, however some back of house functions will be relocated to another community. The applicant is renovating the second floor of the existing structure to maintain two apartments. When completed, the site will feature 6 apartments in total, 1800 square feet of general commercial space, and the existing Funeral Home to remain as is.

In this narrative, we will establish that the project as proposed meets the density and dimensional requirements of the Richmond land development regulations, that the uses proposed are permitted with conditions, and that the design as proposed is consistent with the character of the Village Downtown in form and treatment.

### 3.10 Village Downtown District (VD)

Area: the following parcels are included in this district: PS0023, BR0052, BR0048, BR0039, BR0038, BR0030, BR0027, BR0026, WM0013, EM0010, EM0013, WM0004, WM0035, DS0022, PS0014, BR0072

Purpose: The purpose of the Village Downtown Mixed-Use District is to provide a district that encompasses the existing village core area and supports employment, light industry, commercial enterprises, community gathering spaces, dense and affordable housing, and other compatible uses that bring value to the community and maintain Richmond's unique sense of place. It will also support the traditional village mixed use patterns with street/ground level commercial uses and upper floor residential uses. There are 3 primary goals for this district:

1. Help improve the economic vitality of Richmond by attracting desirable new businesses to the site, creating jobs, and increasing municipal water and wastewater utility use.

The project will create opportunity for new businesses and will use municipal utilities.

2. Attract residents and visitors to our village center for community and commercial activities.

The addition of 4 new units, and the rehabilitation of two more units in the existing funeral home will help bring new residents to the Village Downtown.

- a Increase the housing density, affordability, and diversity in order to support a vibrant and diverse population of Richmond residents. Any development in this district shall enhance the overall village area and shall be compatible with the surrounding mix of residential, non-residential, and municipal uses. Any development proposal shall fit into the vision for Richmond as described in the Richmond Town Plan. 3.10.1

This proposal continues the pattern in the Village Downtown where residential density is on the second and third floors of the commercial structures lining Bridge Street. The modest scale of the proposal, four new units and two rehabilitated units, is in keeping with those examples and compatible with the scale of the Village center.

#### Allowable Uses

Upon Issuance of Zoning Permit by Administrative Officer- The following uses shall be allowed uses in the Village Downtown District upon issuance of a Zoning Permit by the Administrative Officer. Site Plan Review by the DRB shall also be required. More than one principal use per lot is allowed in this district. The most likely permitted uses for the commercial space in this proposal would include:

- a) Artists/Crafts studio
- b) Laundromat
- c) Office, Medical
- d) Office, Professional
- e) Personal Services
- f) Retail business

#### 3.10.2 Allowable Uses Upon Issuance of Conditional Use Approval –

These proposed uses may be allowed in the Village Downtown District after issuance of conditional use approval by the DRB.

- a) Commercial Multi-Use Building
- b) Funeral Parlor Richmond Zoning Regulations 28 Effective May 23, 2022
- c) Planned Unit Development as provided in Section 5.12, if no subdivision of land is proposed (see Section 5.12.1). Residential Dwelling Units as part of a Mixed Use Planned Unit Development



The project as proposed is a mixed-use commercial building where residential dwelling units are included in the mix. The Funeral Parlor is an existing use and will remain. Commercial users are not yet known, but the limited area of the ground floor commercial precludes some allowed uses.

Residential Density and Requirements

a) Each residential dwelling unit shall require 1/24 acre of developable land located on the same lot as the unit subject to the rounding rule below. This equals a residential density of approximately 24 units per acre. Developable land excludes those lands that are outlined in section 2.5.2.

The maximum number of units that may be permitted shall be calculated by multiplying the residential density by the total developable acreage of the lot. When this calculation results in a number of units with a fractional component, the fraction will be rounded according to conventional rounding rules as follows, where X is a whole number: X.0 – X.49 units shall be rounded DOWN to X units. X.50 – X.99 units shall be rounded UP to X+1 units.

The Lot Area is 11,898.26 square feet or .27 acres.	24
units per acre x .27 acres =6.55 Units (Round up to 7)	6

residential units are proposed.

b) Residential dwelling units shall be restricted to the second story/floor and above of any building and shall not be allowed on the street/ground level. These units may be approved as part of a mixed-use Planned Unit Development.

The proposal does not include any ground floor dwelling units. The units are part of a mixed-use PUD as required.

3.10.4 Dimensional Requirement for Lots in the VD District –

No Zoning Permit may be issued for Land Development in the VD District unless the lot proposed for such Land Development meets the following dimensional requirements:

a) Lot Area- No lot shall be less than one-eighth(1/8) or 0.125 acre The purchase of additional land by the owner of a lot from an adjacent lot owner will be permitted, provided such purchase does not create a lot of less than the minimum area required in the Zoning District on the part of the seller.

The Lot Area of the Subject Parcel is 11,898.26 square feet or .27 acres and meets the minimum lot size.

Lot Dimension - Each lot must contain a point from which a circle with a radius of twenty-five (25) feet can be inscribed within the boundary of the lot.

Richmond Zoning Regulations 29 Effective May 23, 2022

The lot is 96.79 feet wide and 153 feet deep and a circle with a 25 foot radius may be inscribed in the lot. See Site Plan.

- b) Lot Frontage- A lot must have 50 feet of continuous frontage on a public or private road, or have
- c) access to a public or private road by a permanent easement or right-of-way approved by the DRB as regulated by Sections 4.2 and 4.3.

The Subject Parcel has 96.79 feet of frontage on Depot Street

- d) Lot Coverage- The total ground area covered by all structures, parking areas, walkways, driveways and areas covered by impervious materials shall not exceed eighty percent (80%) of the total ground area of the lot.

The project as proposed would have a total lot coverage of 79%

A breakdown of coverage types and areas is included on the Site Plan

### 3.10.5 Dimensional Limitations for Structures on Lots in the VD District

- a) Height- shall be as in Section 4.12 of these regulations.

Section 4.12 limits building height to 35 feet. The proposed Building will be 33 feet tall. See Architectural Plans and Elevations.

- b) **Setback- All structures shall have zero (0) feet setbacks, except for a five (5) feet setback for all structures on district boundaries.** All development is required to install and maintain a sidewalk to the public works standards on any and all public road frontage. Placement of the sidewalk and curb cuts or accesses to the property are subject to approval of the Highway Foreman.

The Subject parcel is in the Village Downtown Zone (VD) and the westerly property boundary is on the boundary between the Village Downtown and Residential High-Density District. A five-foot setback is required. The applicant will seek a partial waiver of this requirement.

### 3.10.6 Other Requirements Applicable to Lots in the VD District-

No Zoning Permit may be issued for Land Development in the VD District unless the Land Development meets the following requirements:

a) Parking Requirements

- i) In this district, the residential parking requirement shall be based on the number of bedrooms per dwelling unit. The spaces required shall only serve to calculate overall supply and shall not be assigned to specific dwellings. Spaces shall increase by 0.5 spaces per additional bedroom.

Six two-bedroom apartments require 12 parking spaces and twelve parking spaces are shown on the Site Plan. The applicant will seek parking waivers for the existing use to remain and for the new commercial space based on the potential for shared use, and the availability of public parking on Depot Street.

- ii) All other parking supply requirements shall follow the requirements as set forth in section 6.1.

The most likely commercial tenants would be retail or professional office. That implies a parking rate of 2.5 – 3.5 spaces per 1000 square feet of leasable area. For the 1800 square feet proposed, a range of 4.5 to 6.3 parking spaces are required for the new commercial space. The existing funeral home is grandfathered.

The applicant will seek waivers from the parking requirement as outlined in Section 6.1.6 (p) Waivers - The DRB may waive some or all parking requirements and may place conditions on a waiver as necessary to guarantee adequate parking. The DRB may require any change in use on any property where a waiver has been granted to be reviewed for parking impacts, and the change shall be prohibited if it is deemed to generate a parking deficiency. The DRB shall determine that one or more of the following standards are met at a specific location prior to granting a waiver:

- i. The proposed uses have staggered business hours with minimal overlap in business hours.
- ii. The Applicant presents evidence that the parking requirements are excessive based upon new parking studies, traffic engineering data, or obvious and apparent existing parking demands.
- iii. The Applicant demonstrates that the demand for parking is reduced because the type of business proposed substantially relies on pedestrian traffic.
- iv. The Applicant demonstrates that sufficient off-Road or Highway parking is available at other locations within two hundred (200) feet which are or have been approved by the DRB.
- v. The use of mass transit, or other alternate transportation reduces parking demand.
- vi. Joint parking facilities with abutting businesses are sufficient to meet parking demand.
- vii. The I.T.E. (Institute of Richmond Zoning Regulations 61 Effective May 23, 2022, vii. The I.T.E. (Institute of

Traffic Engineers) Parking Manual, or other professional source, provides data which demonstrates parking demand for a proposed use is less than the standards specified in these Zoning Regulations.”

- b) Loading - Off-Road or Highway loading requirements shall be regulated as provided in Section 6.1
- c) Signs - Signs shall be regulated as provided in Section 5.7.
- d) Traffic Impact - The purpose of this requirement is to foster the general welfare of the public through the minimization of traffic congestion, air pollution, and the risk of motor vehicle and pedestrian accidents.
- g) Residential Use - Residential dwelling units shall be restricted to the second story/floor or higher of any building and shall only be approved and permitted via Planned Unit Development.
- h) Additional Possible Conditions - The following site standards also may be required as a condition of Development Review Board approval
  - Greater setback or screening requirements along the perimeter of the property
  - Adequate pedestrian circulation
  - Demonstration of the ability to properly develop, operate, and maintain development roads, utilities, driveways, parking, sidewalks, landscaping, and other conditions or standards impose

## 5.6 Conditional Use Review

A use requiring conditional use approval by the DRB shall comply with the following general standards and specific standards, and all other applicable standards and requirements of these Zoning Regulations.

### 5.6.1 General Standards –

A proposed use shall not result in an undue adverse effect upon:

- a) The capacity of existing or planned community facilities.

6 apartments and 1800 sf of commercial lease space will likely use community facilities for water and sewer, public parking, and local schools. Richmond is encouraging the addition of new clients to the Town water and sewer utilities.

Two-bedroom apartments may house school aged children, but State data suggests that 6 apartments might contain 1 or 2 students aged grade k-12.

Off street parking requirements are met for the apartments but the ground floor commercial spaces will depend on a combination of existing public parking on Depot Street and shared parking with the apartments. Traffic generation will be modest.

The impact on community services are small enough that I would not consider them adverse. That said, to the extent that any impact in this sensitive area might be construed to be adverse, the scale of the project assures that such impacts are not undue.

- b) The character of the area affected, as defined by the purpose or purposes of the zoning district in which the project is located and with specifically stated policies and standards of the Richmond Town Plan.

The Character of the Village Downtown is established by the unbroken block of late 19<sup>th</sup> early 20<sup>th</sup> century commercial storefronts lining Bridge Street surrounded by stand alone commercial and residential buildings typical of Vermont villages and towns.

The addition of another commercial storefront with upper-level apartments Continues this block pattern while promoting needed growth in the heart of Town. The addition of new housing and modest commercial activity are both well established community goals.

- c) Traffic on roads and highways in the vicinity.

Six apartments will generate 4 vehicle trip ends of Traffic. ITE rates for the commercial space could range from 1.1 to 1.24 VTE per 1000 square feet. This works out to 3 or 4 VTE in the afternoon rush. 8 additional cars will Impact rush hour traffic, but this modest traffic impact is not undue, given the background volume. The project is too small to require a full traffic report.

- d) Bylaws and ordinances then in effect; and,

Other parts of this narrative detail how the project complies with Richmond Zoning Ordinances now in effect.

- e) The utilization of renewable energy sources.

The project when constructed will meet or exceed the RBES (Residential Building Energy Standard). Our current plan is for this building to be all electric. The roof structure will be prepared for solar installation.

5.6.2 Specific Standards - Conditional uses shall comply with the following specific standards:

- a) Obnoxious or excessive noise, smoke, vibration, dust, glare, odors, electrical interference or heat that is detectable at the boundaries of the lot shall not be generated.  
The project as proposed does not include any process emissions.
- b) There shall be no outside displays except those that are brought indoors at the end of the business hours and are the actual product of the business. Richmond Zoning Regulations 45 Effective May 23, 2022  
Project Leases will include a clause that compliments this ordinance.
- c) Outside storage of goods, parts, supplies, vehicles machinery and other personal property shall be appropriate to the neighborhood and shall not impair safety.  
A storage shed for recyclable materials and bicycle storage is proposed.  
Proposed leases will prohibit exterior storage.
- d) A State Wastewater and Potable Water Supply Permit shall be obtained before the use commences.  
The project will comply with State law regarding water and sewer.
- e) The development is proposed over a reasonable time period in order that the general and specific standards for conditional uses may be met.  
This is a single-phase project. Construction will take from 6-8 months depending on the time of year the project starts. The applicant agrees to limit the hours construction activity per the Town Ordinance.
- f) In determining the appropriateness of the use in the Zoning District, the DRB shall consider the scale of the proposal in relation to the scale of existing uses and structures.  
The proposed density and form of the building is consistent with the scale of the Village Downtown.
- g) No fire, explosive, or safety hazard shall be permitted that, in the judgment of the DRB, after consideration of the advice of Richmond firefighting officials, significantly endangers other property owners or emergency personnel.  
As a mixed-use project including apartments, the uses are ordinary hazards. New Construction will comply with NFPA 101, NFPA 1, The IBC and State Construction codes. This project will not include any industrial processes or other special hazards.
- h) The development shall not result in an Undue Adverse Effect on state- or community-owned and operated institutions and facilities.  
The project is not adjacent to any State or Town owned institutions or facilities. Residents will likely use the schools, town library, and other recreational facilities, but the anticipated density is not undue, and such use is not inherently adverse.
- i) Existing water supplies and the quality of ground and surface water resources shall not be adversely affected.

This project will not extract groundwater and it will not provide on-site disposal of wastewater. The property does not abut any surface waters.

- j) The proposed Land Development shall not have an undue adverse effect on an Historic Site or rare or irreplaceable natural areas. Proposed structures should take advantage of existing slopes and vegetation to provide screening for the project.

The buildings that line Bridge Street are historic. The details and scale of this proposal are appropriate for infill development in this context. Being around the corner from the principal streetscape mitigates the visual impact of the addition. Removal of the low framed garages should be acceptable as they are not original to the building, and they do not contribute to the historic character of 22 Depot Street.

This site is currently developed, and so rare natural areas are not found on the subject parcel.

Any other standards, such as natural landscape and “character of the neighborhood” standards, as indicated for specific districts shall also be applied. The DRB may attach such reasonable conditions and safeguards as it may deem necessary to implement the purposes of these Zoning Regulations and 24 V.S.A. Chapter 117.

#### 5.6.3 Site Plan Review Standards –

In order to expedite the review process, conditional uses are not subject to separate site plan review under Section 5.5, however, all conditional uses shall also meet site plan review standards and conditions as set forth under Section 5.5.3 prior to the issuance of conditional use approval.

#### 5.6.4 Conditional Use Review Process –

The DRB shall hold a public hearing on the application, warned in accordance with Section 8.2.3, and shall provide opportunity for any person wishing to achieve status as an Interested Person to demonstrate that they meet the definition of an Interested Person under the Act (24 V.S.A. §4465) and these Zoning Regulations for purposes of participation and appeal. The DRB shall act to approve, approve with conditions, or deny the application and issue a decision as provided in Section 8.2.5.

## 5.12 Planned Unit Development (PUD) and Residential PUD

Purpose – In accordance with the Act (§4417), Planned Unit Developments (PUDs) are authorized within designated zoning districts in order to encourage flexibility of design and the development of land in such a manner as to promote the most appropriate use of land, to facilitate the adequate and economic provision of roads and utilities and to preserve the natural and scenic qualities of the open lands of the Town of Richmond. For purposes of these Zoning Regulations, Residential PUDs shall be considered a type of Planned Unit Development. The modification of the dimensional requirements governing lot area, lot dimension, lot frontage and lot coverage and the dimensional limitations for structures governing front, side and rear yard setback requirements of these Zoning Regulations may be permitted subject to the

### 5.12.1 Coordination of Review –

Applications for PUD or Residential PUD approval shall be reviewed by the DRB as a conditional use, subject to conditional use review and approval under Section 5.6 R Richmond Zoning Regulations 55 Effective May 23, 2022 5.12.3 Additional Standards - In addition to the specific standards in the Zoning District and, as applicable, review standards in Section 5.6 Conditional Use Review, or subdivision review standards under the Town of Richmond Subdivision Regulations, the following site standards also may be required as a condition of the DRB approval.

- a) Greater setback and screening requirements for structures, parking areas and other development features along the perimeter of the property.
- b) Adequate pedestrian circulation.
- c) Improvements to roads to meet the Public Works Specifications.
- d) Restriction of points of access to state or town roads.
- e) Demonstration of the ability to properly develop, operate, and maintain development roads, utilities, and other private improvements.

### Application Procedures –

- a) A Zoning Permit shall not be issued for any building or development in a PUD or Residential PUD until the PUD or Residential PUD has been approved by the DRB.
- b) The DRB shall hold one or more public hearings on the PUD or Residential PUD, warned in accordance with Section 8.2.3, as required for conditional use review.
- c) The Applicant shall submit one set of site plan maps and supporting data to the Administrative Officer for referral to the DRB, which, in addition to the application requirements for conditional use or subdivision review, shall include the following information:



- i. Name and address of the owners of record of adjoining lands. Name and address of person or firm preparing the map. Scale of map, north point, and date. Name, address, and interest of the Applicant in the subject property. (Attached herewith.)
- ii. Survey of the property showing all existing, proposed or potential lot boundaries, and all existing or proposed easements, rights of way and deed restrictions. (Attached herewith.)
- iii. Site resource map, at the same scale as the site plan, showing contours, indicating soils suitable for on-site sewage disposal, wetlands, Areas of Special Flood Hazard, bodies of water, slopes of 20% grade or greater, ridge lines, agricultural and forest land, critical wildlife habitat, and identified natural or historic features. (Attached herewith.)
- iv. Site plan showing the locations of proposed structures and their use; Road(s) or Highway(s), driveways, traffic circulation, parking, and pedestrian ways; landscaping, including site grading, landscape design, and screening; utility lines; lighting; water supply sources and sewage disposal areas; and land that may be set aside for common lands and/or public use. (Attached herewith.)
- v. A statement setting forth the nature of all proposed modifications, changes, or supplements of these Zoning Regulations and the proposed standards and criteria which the Applicant proposes for the development, including standards for the design, bulk and spacing of buildings and sizes of lots and open spaces.  
(As noted elsewhere in this report, the applicant seeks relief from the setback requirement between districts and partial waiver of the parking requirements as allowed with conditions)
- vi. Construction sequence and time schedule for completion of each phase of buildings, Roads or Highways and parking, landscaping and amenities.
- vii. Proposed restrictive covenants for those developments that shall provide common open space, recreation, roads, parking areas, community water and sewer systems, or other facilities owned or maintained in common.

The project is an addition to a single building connected to public utilities. There will not be any new road or utilities constructed beyond connections to existing facilities. The project will be owned by a single entity, so Covenants are not proposed. The applicant has agreed as noted to incorporate community standards for outdoor displays or storage into lease agreements.

A Master Development Plan for any portion of the parcel or lot not proposed for Land Development in the PUD or Residential PUD as of the application date. The Master Development Plan shall conceptually show future roads, building areas, future open areas, and future uses on such remaining land. (This requirement is not applicable to the proposed project. No portion of this site will be retained for future development.)

#### 5.12.7 PUD and Residential PUD Review Process-

The PUD or PUD and Master Development Plan decision will be issued concurrently with the conditional use or final subdivision plan decision. The DRB shall hold a public hearing on the application, warned in accordance with Section 8.2 and shall provide opportunity for any person wishing to achieve status as an Interested Person to demonstrate that they meet the definition of “Interested Person” under the Act (§4465) and these Zoning Regulations for purposes of appeal. The DRB shall act to approve, approve with conditions, or deny the application and issue a decision as provided in Section 8.2.

Abutting Property Owners: 22 Depot Street

Notice and supporting materials have been sent to these abutting property owners:

72 Bridge Street  
SPAN 519-163-10425  
Novak Real Estate LLC.

Po Box 43, Bridge St, Richmond, Vt, 05477, USA

44 Depot Street  
SPAN 519-163-10765  
Estate of Bruce Jacobs

35 Main Street  
SPAN 519-163-10765  
Cindy Feloney

C/o Cindy Feloney 35 W Main St, Apt 3, Richmond, VT, 05477-4452

60 Bridge Street - 6 Depot Street  
SPAN 519-163-11099  
North Star Lodge

C/o James Chase, 52 Bridge Street, Richmond Vermont 05477

50 Bridge Street  
SPAN 519-163-10117  
In The Block LLC.

C/o Jeremy D. Hoff, Esq., 26 Bridge Street, Richmond, Vt, 05477

40-44 Bridge Street  
SPAN 519-163-10116 Sweet  
Suites LLC.

C/o Lisa Curtis ,35 Blackberry Lane, Huntington VT 05462



## 22 Depot Street

### Landscape Maintenance Plan for Trees and Shrubs

Task	Description
<b>April</b>	
Prune trees and shrubs	Prune shade trees and hedges as required. <ul style="list-style-type: none"><li>• Prune evergreen hedge to maintain desired height and distance from parking lot (typically 2'+/-). Do not remove more than 1/3 of the volume of the shrub without prior approval from the owner.</li><li>• Prune any dead or damaged branches from trees or shrubs disposing of any diseased leaves.</li><li>• Prune trees so that all branches are at least 5 feet away from the building or shed. Do not remove more than 1/3 of the volume of the tree without prior approval from the property manager.</li></ul>
Fertilize Trees	Apply 10-10-10 granular fertilizer at the base of trees and shrubs per manufacturer's recommendations.
Remove tree stakes	Remove any tree stakes or watering bags from the previous season.
Spring cleanup	Clean up, edge planting beds and mulch <ul style="list-style-type: none"><li>• Remove dead leaves from deciduous trees in planting beds before mulching.</li><li>• Remove weeds from the root in planting beds and tree rings. (Cutting weeds to the ground is not acceptable.)</li><li>• All Red Maple deciduous trees will have at least a 3' wide mulch ring from the trunk of the tree.</li><li>• Spade edge planting beds/mulch rings to define the bed line.</li><li>• Remove buildup of old mulch in planting beds and around the base of trees and shrubs.</li><li>• Apply 1" of shredded pine bark mulch in all planting beds and mulch rings keeping away from the bark of trees and shrubs</li></ul>
<b>June</b>	
One garden visit	Remove weeds from the root in planting beds and tree rings. (Cutting weeds to the ground is not acceptable.)
Replacements	Replace trees and shrubs that did not survive the winter.
<b>July</b>	
Pruning shrubs & hedges	Prune any dead or dying branches from trees or shrubs disposing of any diseased leaves.
Two garden visits	Remove weeds from the root in planting beds and tree rings. (Cutting weeds to the ground is not acceptable.) Water any replacements from June.
<b>August</b>	
Fertilizer application	Apply 10,10,10 granular fertilizer according to manufacturer's recommendations at the base of shrubs and trees planted within the last 3 years.
Two garden visits	Remove weeds from the root in planting beds, tree rings, 'drip strips,' hardscaped areas and adjacent to buildings. (Cutting weeds to the ground is not acceptable.) Water any replacements from June.
<b>September</b>	
Replacements	Replace shrubs or perennials that did not survive the summer..





**Gardco EcoForm Gen-2** combines economy with performance in an LED area luminaire. Capable of delivering up to 27,800 lumens or more in a compact, low profile LED luminaire, EcoForm offers a new level of customer value. EcoForm features an innovative retrofit arm kit, simplifying site conversions to LED by eliminating the need to drill additional holes in most existing poles. Integral control systems available for further energy savings. Includes Service Tag, our innovative way to provide assistance throughout the life of the product.

Project: \_\_\_\_\_  
 Location: \_\_\_\_\_  
 Cat.No: \_\_\_\_\_  
 Type: \_\_\_\_\_  
 Lamps: \_\_\_\_\_ Qty: \_\_\_\_\_  
 Notes: \_\_\_\_\_

example: ECF-S-64L-900-NW-G2-AR-5-120-HIS-MGY

**Ordering guide**

Prefix		Number of LEDs	Drive Current	LED Color - Generation	Mounting	Distribution	Voltage			
<b>ECF-S</b>										
ECF-S	EcoForm site and area, small	32L 32 LEDs (2 modules)	365 365mA	WW-G2 Warm White 3000K, 70CRI Generation 2 NW-G2 Neutral White 4000K, 70CRI Generation 2 CW-G2 Cool White 5000K, 70CRI Generation 2	AR <sup>2</sup> Arm Mount (standard)  The following mounting kits must be ordered separately (See accessories)  SF <sup>3</sup> Slip Fitter Mount (fits to 2 3/8" O.D. tenon) WS Wall mount with surface conduit rear entry permitted RAM <sup>2</sup> Retrofit arm mount kit	<b>Type 2</b> 2 Type 2 2-90 Rotated left 90° 2-270 Rotated right 270° <b>Type 3</b> 3 Type 3 3-90 Rotated left 90° 3-270 Rotated right 270° <b>Type 4</b> 4 Type 4 4-90 Rotated left 90° 4-270 Rotated right 270° <b>Type 5</b> 5 Type 5 5W Type 5W	120 120V 208 208V 240 240V 277 277V 347 347V 480 480V UNV 120-277V (50/60Hz) HVU 347-480V (50/60Hz)			
			530 530mA					700 700mA	1A 1050mA	1.2A 1200mA
			900 900mA					1A 1050mA	1.2A <sup>19</sup> 1200mA	
		48L 48 LEDs (3 modules)	900 900mA							
		64L 64 LEDs (4 modules)	900 900mA							
			1A <sup>19</sup> 1050mA							

Options						
Dimming controls	Motion sensing lens	Photo-sensing	Electrical	Luminaire	Finish	
DD <sup>4,18</sup> 0-10V External dimming (for controls by others) DCC <sup>4,5,6,18</sup> Dual Circuit Control FAWS <sup>4,6,18</sup> Field Adjustable Wattage Selector LLC <sup>4,6,7,8,18</sup> Integral wireless module BL <sup>1,4,7,18</sup> Bi-level functionality SRDR <sup>4,5,6,8,17</sup> SR driver connected to Zhaga socket  <b>DynaDimmer: Automatic Profile Dimming</b> CS50 <sup>4,8</sup> Safety 50% Dimming, 7 hours CM50 <sup>4,8</sup> Median 50% Dimming, 8 hours CS30 <sup>4,8</sup> Safety 30% Dimming, 7 hours CM30 <sup>4,8</sup> Median 30% Dimming, 8 hours	IMR13 <sup>15</sup> Integral with #3 lens IMR17 <sup>16</sup> Integral with #7 lens	PCB <sup>8,9</sup> Photocontrol Button TLRD5 <sup>10,17</sup> Twist Lock Receptacle 5 Pin TLRD7 <sup>10,17</sup> Twist Lock Receptacle 7 Pin TLRPC <sup>9,10,11,17</sup> Twist Lock Receptacle w/ Photocell	<b>Fusing</b> F1 <sup>9</sup> Single (120, 277, 347VAC) F2 <sup>9</sup> Double (208, 240, 480VAC) <b>Pole Mount Fusing</b> FP1 <sup>9</sup> Single (120, 277, 347VAC) FP2 <sup>9</sup> Double (208, 240, 480VAC) FP3 <sup>9</sup> Canadian Double Pull (208, 240, 480VAC) <b>Surge Protection (10kA standard)</b> SP2 Increased 20kA	Square Pole Adapter included in standard product TB <sup>12</sup> Terminal Block RPA <sup>13</sup> Round Pole Adapter (fits to 3"- 3.9" O.D. pole) HIS <sup>14</sup> Internal House Side Shield	<b>Textured</b> BK Black WH White BZ Bronze DGY Dark Gray MGY Medium Gray  <b>Customer specified</b> RAL Specify optional color or RAL (ex: RAL7024) CC Custom color (Must supply color chip for required factory quote)	

- BL-IMR13/7 equipped with out-boarded sensor housing when voltage is HVU (347-480V)
- Mounts to a 4" round pole with adapter included for square poles.
- Limited to a maximum of 45 degrees aiming above horizontal.
- Not available with other dimming control options.
- Not available with motion sensor.
- Not available with photocontrol.
- Must specify a motion sensor lens.
- Not available in 347 or 480V
- Must specify input voltage.
- TLRD5, TLRD7 and TLRPC receptacle pins 4 & 5 are capped off when ordered with any of the Dimming controls DD or FAWS or LLC.
- Not available in 480V. Order photocell separately with TLRD5/7.
- Not available with DCC.
- Not available with SF and WS. RPAs provided with black finish standard.
- HIS not available with Type 5, 5W, BLC, BLC-90, BLC-270, LCL or RCL optics.
- Not available with DD, DCC, and FAWS dimming control options.
- Not available with DD, DCC, FAWS and LLC dimming control options.
- When ordering SRDR, controller (by others) to be used on socket must be SR compatible (See specifications for more details). Consult factory for lead time. All 7 pins in NEMA receptacle are connected to SR driver. SRDR not available with TLRD5 or TLRPC.
- 0-10V dimming driver standard.
- LCL and RCL not available with 48L-1.2A or 64L-1A.



# ECF-S EcoForm small

## Area luminaire

EcoForm Accessories<sup>21</sup> (ordered separately, field installed)

### Shielding Accessories

#### House Side shield

Standard optic orientation:

**HIS-32-H**<sup>20</sup> Internal House Side Shield for 32 LEDs (2 modules)

**HIS-48-H**<sup>20</sup> Internal House Side Shield for 48 LEDs (3 modules)

**HIS-64-H**<sup>20</sup> Internal House Side Shield for 64 LEDs (4 modules)

Optic at 90 or 270 orientation:

**HIS-32-V**<sup>20</sup> Internal House Side Shield for 32 LEDs (2 modules)

**HIS-48-V**<sup>20</sup> Internal House Side Shield for 48 LEDs (3 modules)

**HIS-64-V**<sup>20</sup> Internal House Side Shield for 64 LEDs (4 modules)

### Luminaire Accessories

**ECF-BD-G2** Bird deterrent  
**ECF-RAM-G2-(F)** Retrofit Arm mount kit  
**ECF-SF-G2-(F)** Slip Fitter Mount (fits to 2 3/8" O.D. tenon)  
**ECF-WS-G2-(F)** Wall mount with surface conduit rear entry permitted

**EcoForm PTF2**  
 (pole top fitter fits 23/8-21/2" OD x 4" depth tenon)

**PTF2-ECF-S/L-1-90-(F)** 1 luminaire at 90°  
**PTF2-ECF-S/L-2-90-(F)** 2 luminaires at 90°  
**PTF2-ECF-S/L-2-180-(F)** 2 luminaires at 180°  
**PTF2-ECF-S/L-3-90-(F)** 3 luminaires at 90°  
**PTF2-ECF-S/L-4-90-(F)** 4 luminaires at 90°  
**PTF2-ECF-S/L-3-120-(F)** 3 luminaires at 120°

(F) = Specify finish

**EcoForm PTF3**  
 (pole top fitter fits 3-31/2" OD x 6" depth tenon)

**PTF3-ECF-S/L-1-90-(F)** 1 luminaire at 90°  
**PTF3-ECF-S/L-2-90-(F)** 2 luminaires at 90°  
**PTF3-ECF-S/L-2-180-(F)** 2 luminaires at 180°  
**PTF3-ECF-S/L-3-90-(F)** 3 luminaires at 90°  
**PTF3-ECF-S/L-4-90-(F)** 4 luminaires at 90°  
**PTF3-ECF-S/L-3-120-(F)** 3 luminaires at 120°

**EcoForm PTF4**  
 (pole top fitter fits 31/2-4" OD x 6" depth tenon)

**PTF4-ECF-S/L-1-90-(F)** 1 luminaire at 90°  
**PTF4-ECF-S/L-2-90-(F)** 2 luminaires at 90°  
**PTF4-ECF-S/L-2-180-(F)** 2 luminaires at 180°  
**PTF4-ECF-S/L-3-90-(F)** 3 luminaires at 90°  
**PTF4-ECF-S/L-4-90-(F)** 4 luminaires at 90°  
**PTF4-ECF-S/L-3-120-(F)** 3 luminaires at 120°

### Footnotes

20. Not available with Type 5 or 5W optics

21. Consult Signify to confirm whether specific accessories are BAA-compliant.

**Ready to Go configurations** (when ordered with the "RS-" catalog code, the following configurations will ship in 2 weeks):

Catalog Number	12NC
RS-ECF-S-32L-1A-NW-G2-AR-3-UNV-BZ	912401466002
RS-ECF-S-32L-1A-NW-G2-AR-3-UNV-MGY	912401466003
RS-ECF-S-32L-1A-NW-G2-AR-3-UNV-BK	912401534554
RS-ECF-S-32L-1A-NW-G2-AR-4-UNV-BZ	912401466004
RS-ECF-S-32L-1A-NW-G2-AR-4-UNV-MGY	912401466005
RS-ECF-S-32L-1A-NW-G2-AR-4-UNV-BK	912401534555
RS-ECF-S-32L-1A-NW-G2-AR-5-UNV-BZ	912401466006
RS-ECF-S-32L-1A-NW-G2-AR-5-UNV-MGY	912401466007
RS-ECF-S-32L-1A-NW-G2-AR-5-UNV-BK	912401534556
RS-ECF-S-48L-1A-NW-G2-AR-3-UNV-BZ	912401466008
RS-ECF-S-48L-1A-NW-G2-AR-3-UNV-MGY	912401466009
RS-ECF-S-48L-1A-NW-G2-AR-3-UNV-BK	912401534557
RS-ECF-S-48L-1A-NW-G2-AR-4-UNV-BZ	912401466010
RS-ECF-S-48L-1A-NW-G2-AR-4-UNV-MGY	912401466011
RS-ECF-S-48L-1A-NW-G2-AR-4-UNV-BK	912401534558
RS-ECF-S-48L-1A-NW-G2-AR-5-UNV-BZ	912401466012
RS-ECF-S-48L-1A-NW-G2-AR-5-UNV-MGY	912401466013
RS-ECF-S-48L-1A-NW-G2-AR-5-UNV-BK	912401534559
RS-ECF-S-64L-1A-NW-G2-AR-3-UNV-BZ	912401466014
RS-ECF-S-64L-1A-NW-G2-AR-3-UNV-MGY	912401466015

Catalog Number	12NC
RS-ECF-S-64L-1A-NW-G2-AR-3-UNV-BK	912401534560
RS-ECF-S-64L-1A-NW-G2-AR-4-UNV-BZ	912401466016
RS-ECF-S-64L-1A-NW-G2-AR-4-UNV-MGY	912401466017
RS-ECF-S-64L-1A-NW-G2-AR-4-UNV-BK	912401534561
RS-ECF-S-64L-1A-NW-G2-AR-5-UNV-BZ	912401466018
RS-ECF-S-64L-1A-NW-G2-AR-5-UNV-MGY	912401466019
RS-ECF-S-64L-1A-NW-G2-AR-5-UNV-BK	912401534562
RS-ECF-RAM-G2-DGY	912401466487
RS-ECF-RAM-G2-MGY	912401466488
RS-ECF-RAM-G2-WH	912401466485
RS-ECF-RAM-G2-BZ	912401466486
RS-ECF-RAM-G2-BK	912401466484
RS-HIS-32-H	912401466489
RS-HIS-48-H	912401466491
RS-HIS-64-H	912401466493



# ECF-S EcoForm small

## Area luminaire

### Predicted Lumen Depreciation Data

Predicted performance derived from LED manufacturer's data and engineering design estimates, based on IESNA LM-80 methodology. Actual experience may vary due to field application conditions. L<sub>70</sub> is the predicted time when LED performance depreciates to 70% of initial lumen output. Calculated per IESNA TM21-11. Published L<sub>70</sub> hours limited to 6 times actual LED test hours

Ambient Temperature °C	Driver mA	Calculated L <sub>70</sub> Hours	L <sub>70</sub> per TM-21	Lumen Maintenance % at 60,000 hrs
25°C	up to 1200 mA	>100,000 hours	>120,000 hours	>99%

### Optical Distributions

Based on configuration ECF-S-48L-1A-NW-G2 (159W) mounted at 20ft.

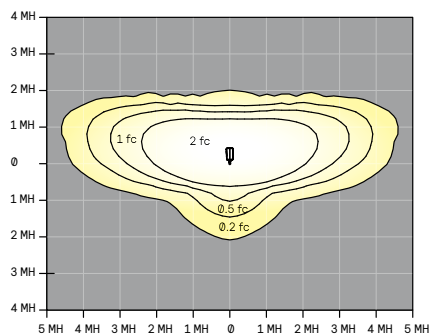

Type 2

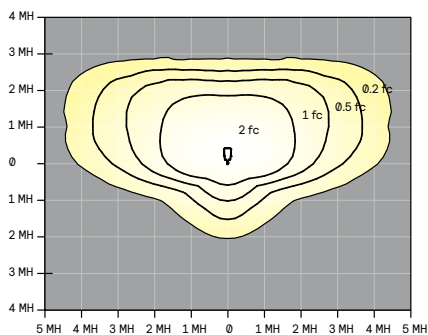

Type 3

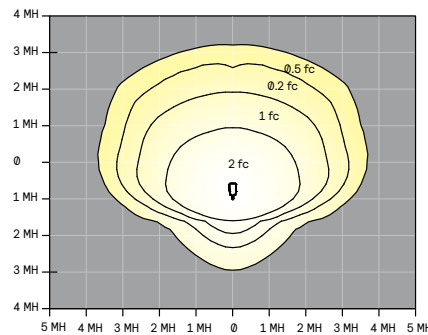

Type 4

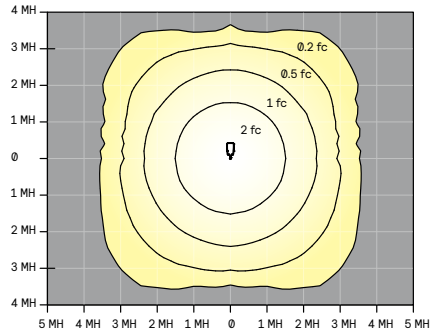

Type 5

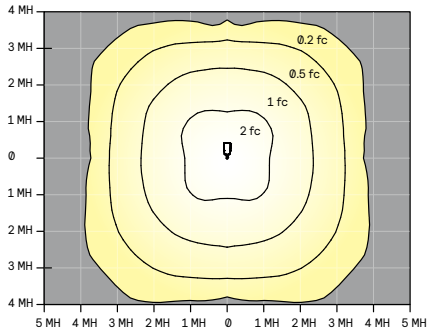

Type 5W

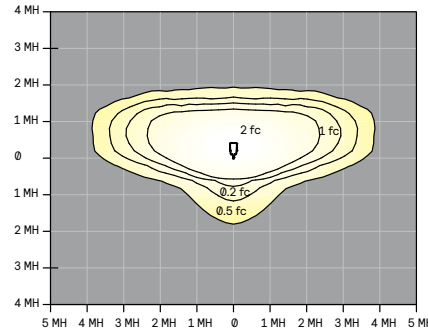

AFR

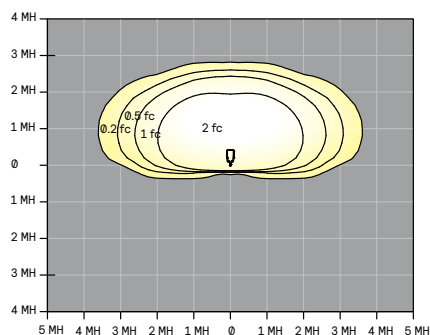

BLC

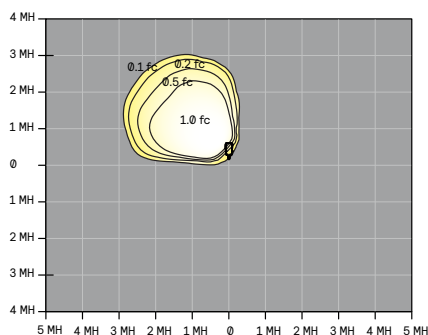

LCL

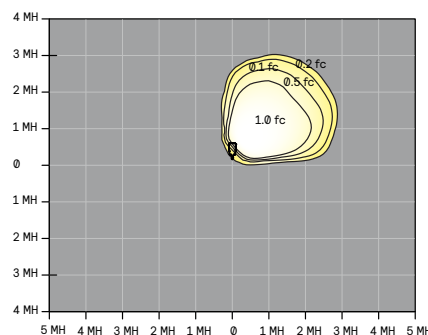

RCL

# ECF-S EcoForm small

## Area luminaire

### 3000K LED Wattage and Lumen Values

Ordering Code	Total LEDs	LED Current (mA)	Color Temp.	Average System Watts	Type 2			Type 3			Type 4			Type 5			Type 5W		
					Lumen Output	BUG Rating	Efficacy (LPW)	Lumen Output	BUG Rating	Efficacy (LPW)	Lumen Output	BUG Rating	Efficacy (LPW)	Lumen Output	BUG Rating	Efficacy (LPW)	Lumen Output	BUG Rating	Efficacy (LPW)
ECF-S-32L-365-WW-G2-x	32	365	3000	40	5,508	B1-U0-G1	138	5,428	B1-U0-G2	136	5,637	B1-U0-G2	141	5,790	B3-U0-G1	145	5,604	B3-U0-G1	140
ECF-S-32L-530-WW-G2-x	32	530	3000	56	7,159	B2-U0-G2	129	7,055	B1-U0-G2	127	7,327	B1-U0-G2	132	7,526	B3-U0-G2	135	7,284	B3-U0-G2	131
ECF-S-32L-700-WW-G2-x	32	700	3000	73	9,234	B2-U0-G2	127	9,034	B2-U0-G2	124	9,452	B2-U0-G2	130	9,707	B4-U0-G2	133	9,395	B4-U0-G2	129
ECF-S-32L-1A-WW-G2-x	32	1050	3000	106	13,001	B3-U0-G2	123	12,719	B2-U0-G2	120	13,306	B2-U0-G3	126	13,665	B4-U0-G2	129	13,227	B4-U0-G2	125
ECF-S-32L-1.2A-WW-G2-x	32	1200	3000	122	14,421	B3-U0-G3	119	14,108	B2-U0-G3	116	14,760	B2-U0-G3	121	15,158	B4-U0-G2	125	14,671	B4-U0-G2	121
ECF-S-48L-900-WW-G2-x	48	900	3000	135	17,115	B3-U0-G3	127	16,744	B3-U0-G3	124	17,518	B2-U0-G3	130	17,990	B4-U0-G2	133	17,413	B5-U0-G3	129
ECF-S-48L-1A-WW-G2-x	48	1050	3000	159	19,381	B3-U0-G3	122	18,960	B3-U0-G3	119	19,836	B3-U0-G4	125	20,372	B5-U0-G3	128	19,717	B5-U0-G3	124
ECF-S-48L-1.2A-WW-G2-x	48	1200	3000	183	21,515	B3-U0-G3	118	21,048	B3-U0-G4	115	22,020	B3-U0-G4	121	22,616	B5-U0-G3	124	21,888	B5-U0-G3	120
ECF-S-64L-900-WW-G2-x	64	900	3000	178	22,652	B3-U0-G3	127	22,161	B3-U0-G4	125	23,185	B3-U0-G4	130	23,810	B5-U0-G3	134	23,045	B5-U0-G3	130
ECF-S-64L-1A-WW-G2-x	64	1050	3000	206	25,520	B3-U0-G3	124	24,966	B3-U0-G4	121	26,120	B3-U0-G4	127	26,150	B5-U0-G3	127	25,964	B5-U0-G4	126

Ordering Code	Total LEDs	LED Current (mA)	Color Temp.	Average System Watts	Type AFR			BLC			LCL or RCL		
					Lumen Output	BUG Rating	Efficacy (LPW)	Lumen Output	BUG Rating	Efficacy (LPW)	Lumen Output	BUG Rating	Efficacy (LPW)
ECF-S-32L-365-WW-G2-x	32	365	3000	40	5,706	B2-U0-G1	143	3,691	B0-U0-G1	94	2,449	B0-U0-G1	62
ECF-S-32L-530-WW-G2-x	32	530	3000	56	7,417	B2-U0-G1	133	5,005	B0-U0-G2	91	3,183	B0-U0-G1	58
ECF-S-32L-700-WW-G2-x	32	700	3000	73	9,567	B2-U0-G2	131	6,409	B0-U0-G2	89	4,106	B0-U0-G1	57
ECF-S-32L-1A-WW-G2-x	32	1050	3000	106	13,467	B3-U0-G2	128	9,024	B1-U0-G2	87	5,793	B0-U0-G2	56
ECF-S-32L-1.2A-WW-G2-x	32	1200	3000	122	14,939	B3-U0-G2	123	10,010	B1-U0-G2	84	6,426	B0-U0-G2	54
ECF-S-48L-900-WW-G2-x	48	900	3000	135	17,731	B3-U0-G2	131	11,880	B1-U0-G2	89	7,626	B0-U0-G2	57
ECF-S-48L-1A-WW-G2-x	48	1050	3000	159	20,076	B3-U0-G2	127	13,453	B1-U0-G2	86	8,636	B0-U0-G2	55
ECF-S-48L-1.2A-WW-G2-x	48	1200	3000	183	22,288	B3-U0-G2	122	14,934	B1-U0-G3	83			
ECF-S-64L-900-WW-G2-x	64	900	3000	178	23,465	B3-U0-G2	132	15,723	B1-U0-G3	90	10,093	B0-U0-G2	58
ECF-S-64L-1A-WW-G2-x	64	1050	3000	206	26,437	B4-U0-G3	128	17,714	B1-U0-G3	87			

### 4000K LED Wattage and Lumen Values

Ordering Code	Total LEDs	LED Current (mA)	Color Temp.	Average System Watts	Type 2			Type 3			Type 4			Type 5			Type 5W		
					Lumen Output	BUG Rating	Efficacy (LPW)	Lumen Output	BUG Rating	Efficacy (LPW)	Lumen Output	BUG Rating	Efficacy (LPW)	Lumen Output	BUG Rating	Efficacy (LPW)	Lumen Output	BUG Rating	Efficacy (LPW)
ECF-S-32L-365-NW-G2-x	32	365	4000	40	5,798	B1-U0-G1	145	5,713	B1-U0-G2	143	5,934	B1-U0-G2	148	6,094	B3-U0-G1	152	5,898	B3-U0-G2	147
ECF-S-32L-530-NW-G2-x	32	530	4000	56	7,536	B2-U0-G2	135	7,426	B1-U0-G2	133	7,713	B1-U0-G2	138	7,922	B3-U0-G2	142	7,667	B3-U0-G2	138
ECF-S-32L-700-NW-G2-x	32	700	4000	73	9,720	B2-U0-G2	133	9,509	B2-U0-G2	130	9,949	B2-U0-G2	136	10,218	B4-U0-G2	140	9,889	B4-U0-G2	136
ECF-S-32L-1A-NW-G2-x	32	1050	4000	106	13,685	B3-U0-G2	130	13,388	B2-U0-G3	127	14,006	B2-U0-G3	133	14,384	B4-U0-G2	136	13,923	B4-U0-G2	132
ECF-S-32L-1.2A-NW-G2-x	32	1200	4000	122	15,180	B3-U0-G3	125	14,851	B2-U0-G3	122	15,537	B2-U0-G3	128	15,956	B4-U0-G2	131	15,443	B4-U0-G2	127
ECF-S-48L-900-NW-G2-x	48	900	4000	135	18,016	B3-U0-G3	133	17,625	B3-U0-G3	130	18,440	B3-U0-G3	136	18,937	B4-U0-G3	140	18,329	B5-U0-G3	136
ECF-S-48L-1A-NW-G2-x	48	1050	4000	159	20,401	B3-U0-G3	129	19,958	B3-U0-G4	126	20,880	B3-U0-G4	132	21,444	B5-U0-G3	135	20,755	B5-U0-G3	131
ECF-S-48L-1.2A-NW-G2-x	48	1200	4000	183	22,647	B3-U0-G3	124	22,156	B3-U0-G4	121	23,179	B3-U0-G4	127	23,806	B5-U0-G3	130	23,040	B5-U0-G3	126
ECF-S-64L-900-NW-G2-x	64	900	4000	178	23,844	B3-U0-G3	134	23,327	B3-U0-G4	131	24,405	B3-U0-G4	137	25,063	B5-U0-G3	141	24,258	B5-U0-G4	136
ECF-S-64L-1A-NW-G2-x	64	1050	4000	206	26,863	B3-U0-G3	130	26,280	B3-U0-G4	128	27,495	B3-U0-G4	134	27,526	B5-U0-G3	134	27,330	B5-U0-G4	133

Ordering Code	Total LEDs	LED Current (mA)	Color Temp.	Average System Watts	Type AFR			BLC			LCL or RCL		
					Lumen Output	BUG Rating	Efficacy (LPW)	Lumen Output	BUG Rating	Efficacy (LPW)	Lumen Output	BUG Rating	Efficacy (LPW)
ECF-S-32L-365-NW-G2-x	32	365	4000	40	6,006	B2-U0-G1	150	3,991	B0-U0-G1	101	2,633	B0-U0-G1	67
ECF-S-32L-530-NW-G2-x	32	530	4000	56	7,807	B2-U0-G1	140	5,412	B0-U0-G2	99	3,423	B0-U0-G1	62
ECF-S-32L-700-NW-G2-x	32	700	4000	73	10,070	B2-U0-G2	138	6,930	B0-U0-G2	96	4,415	B0-U0-G1	61
ECF-S-32L-1A-NW-G2-x	32	1050	4000	106	14,176	B3-U0-G2	134	9,756	B1-U0-G2	94	6,229	B0-U0-G2	60
ECF-S-32L-1.2A-NW-G2-x	32	1200	4000	122	15,725	B3-U0-G2	129	10,822	B1-U0-G2	90	6,910	B0-U0-G2	58
ECF-S-48L-900-NW-G2-x	48	900	4000	135	18,664	B3-U0-G2	138	12,843	B1-U0-G2	96	8,200	B0-U0-G2	62
ECF-S-48L-1A-NW-G2-x	48	1050	4000	159	21,133	B3-U0-G2	133	14,544	B1-U0-G3	93	9,286	B0-U0-G2	59
ECF-S-48L-1.2A-NW-G2-x	48	1200	4000	183	23,461	B3-U0-G2	128	16,145	B1-U0-G3	90			
ECF-S-64L-900-NW-G2-x	64	900	4000	178	24,700	B3-U0-G2	139	16,998	B1-U0-G3	97	10,853	B0-U0-G2	62
ECF-S-64L-1A-NW-G2-x	64	1050	4000	206	27,828	B4-U0-G3	135	19,150	B1-U0-G3	94			

# ECF-S EcoForm small

## Area luminaire

### 5000K LED Wattage and Lumen Values

Ordering Code	Total LEDs	LED Current (mA)	Color Temp.	Average System Watts	Type 2			Type 3			Type 4			Type 5			Type 5W		
					Lumen Output	BUG Rating	Efficacy (LPW)	Lumen Output	BUG Rating	Efficacy (LPW)	Lumen Output	BUG Rating	Efficacy (LPW)	Lumen Output	BUG Rating	Efficacy (LPW)	Lumen Output	BUG Rating	Efficacy (LPW)
ECF-S-32L-365-CW-G2-x	32	365	5000	40	5,798	B1-U0-G1	145	5,713	B1-U0-G2	143	5,934	B1-U0-G2	148	6,094	B3-U0-G1	152	5,898	B3-U0-G2	147
ECF-S-32L-530-CW-G2-x	32	530	5000	56	7,536	B2-U0-G2	135	7,426	B1-U0-G2	133	7,713	B1-U0-G2	138	7,922	B3-U0-G2	142	7,667	B3-U0-G2	138
ECF-S-32L-700-CW-G2-x	32	700	5000	73	9,720	B2-U0-G2	133	9,509	B2-U0-G2	130	9,949	B2-U0-G2	136	10,218	B4-U0-G2	140	9,889	B4-U0-G2	136
ECF-S-32L-1A-CW-G2-x	32	1050	5000	106	13,685	B3-U0-G2	130	13,388	B2-U0-G3	127	14,006	B2-U0-G3	133	14,384	B4-U0-G2	136	13,923	B4-U0-G2	132
ECF-S-32L-1.2A-CW-G2-x	32	1200	5000	122	15,180	B3-U0-G3	125	14,851	B2-U0-G3	122	15,537	B2-U0-G3	128	15,956	B4-U0-G2	131	15,443	B4-U0-G2	127
ECF-S-48L-900-CW-G2-x	48	900	5000	135	18,016	B3-U0-G3	133	17,625	B3-U0-G3	130	18,440	B3-U0-G3	136	18,937	B4-U0-G3	140	18,329	B5-U0-G3	136
ECF-S-48L-1A-CW-G2-x	48	1050	5000	159	20,401	B3-U0-G3	129	19,958	B3-U0-G4	126	20,880	B3-U0-G4	132	21,444	B5-U0-G3	135	20,755	B5-U0-G3	131
ECF-S-48L-1.2A-CW-G2-x	48	1200	5000	183	22,647	B3-U0-G3	124	22,156	B3-U0-G4	121	23,179	B3-U0-G4	127	23,806	B5-U0-G3	130	23,040	B5-U0-G3	126
ECF-S-64L-900-CW-G2-x	64	900	5000	178	23,844	B3-U0-G3	134	23,327	B3-U0-G4	131	24,405	B3-U0-G4	137	25,063	B5-U0-G3	141	24,258	B5-U0-G4	136
ECF-S-64L-1A-CW-G2-x	64	1050	5000	206	26,863	B3-U0-G3	130	26,280	B3-U0-G4	128	27,495	B3-U0-G4	134	27,526	B5-U0-G3	134	27,330	B5-U0-G4	133

Ordering Code	Total LEDs	LED Current (mA)	Color Temp.	Average System Watts	Type AFR			BLC			LCL or RCL		
					Lumen Output	BUG Rating	Efficacy (LPW)	Lumen Output	BUG Rating	Efficacy (LPW)	Lumen Output	BUG Rating	Efficacy (LPW)
ECF-S-32L-365-CW-G2-x	32	365	5000	40	6,006	B2-U0-G1	150	3,991	B0-U0-G1	101	2,633	B0-U0-G1	67
ECF-S-32L-530-CW-G2-x	32	530	5000	56	7,807	B2-U0-G1	140	5,412	B0-U0-G2	99	3,423	B0-U0-G1	62
ECF-S-32L-700-CW-G2-x	32	700	5000	73	10,070	B2-U0-G2	138	6,930	B0-U0-G2	96	4,415	B0-U0-G1	61
ECF-S-32L-1A-CW-G2-x	32	1050	5000	106	14,176	B3-U0-G2	134	9,756	B1-U0-G2	94	6,229	B0-U0-G2	60
ECF-S-32L-1.2A-CW-G2-x	32	1200	5000	122	15,725	B3-U0-G2	129	10,822	B1-U0-G2	90	6,910	B0-U0-G2	58
ECF-S-48L-900-CW-G2-x	48	900	5000	135	18,664	B3-U0-G2	138	12,843	B1-U0-G2	96	8,200	B0-U0-G2	62
ECF-S-48L-1A-CW-G2-x	48	1050	5000	159	21,133	B3-U0-G2	133	14,544	B1-U0-G3	93	9,286	B0-U0-G2	59
ECF-S-48L-1.2A-CW-G2-x	48	1200	5000	183	23,461	B3-U0-G2	128	16,145	B1-U0-G3	90			
ECF-S-64L-900-CW-G2-x	64	900	5000	178	24,700	B3-U0-G2	139	16,998	B1-U0-G3	97	10,853	B0-U0-G2	62
ECF-S-64L-1A-CW-G2-x	64	1050	5000	206	27,828	B4-U0-G3	135	19,150	B1-U0-G3	94			

# ECF-S EcoForm small

## Area lumineuse

### Dimensions

#### Standard Arm (AR)

Weight: 22 Lbs (9.9 Kg) EPA: 0.21ft<sup>2</sup> (.019m<sup>2</sup>)

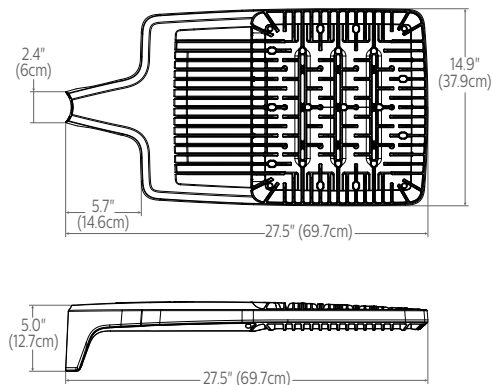

#### Wall (WS)

Weight: 27 Lbs. (12. 2Kg)EPA: 0.27ft<sup>2</sup> (.025m<sup>2</sup>)

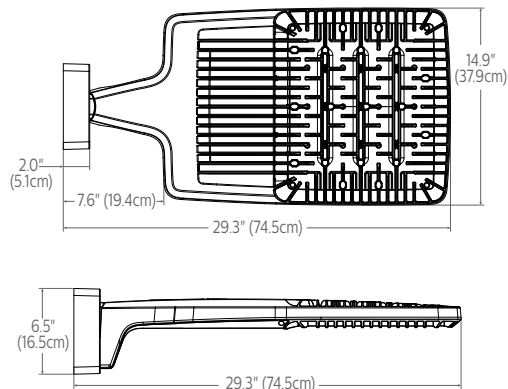

#### Retrofit Arm (RAM)

Weight: 24 Lbs (10.9 Kg) EPA: 0.24ft<sup>2</sup> (.022m<sup>2</sup>)

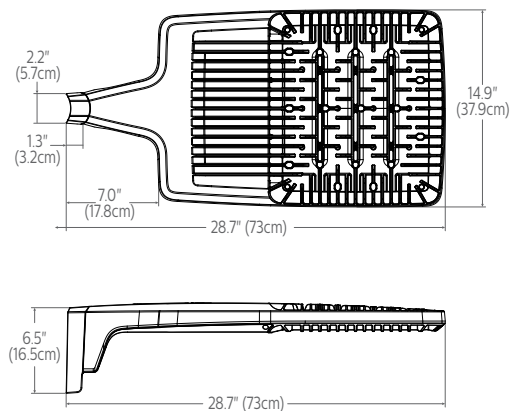

#### Slip fitter (SF)

Weight: 27 Lbs (12.2 Kg) EPA: 0.33ft<sup>2</sup> (.031m<sup>2</sup>)

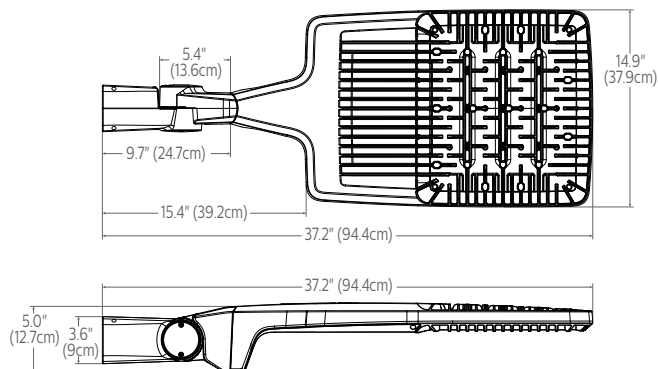

#### Outboard IMR-HVU sensor

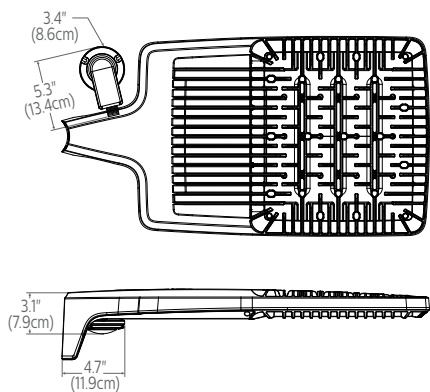

#### Standard Arm (AR) drill pattern

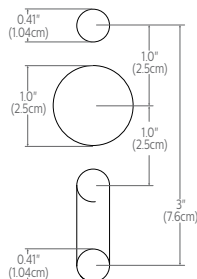

#### Retrofit Arm (RAM) drill pattern

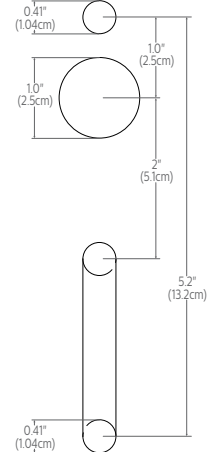

# ECF-S EcoForm small

## Area luminaire

### Optical Orientation Information

#### Standard Optic Position

Luminaires ordered with asymmetric optical systems in the standard optic position will have the optical system oriented as shown below:

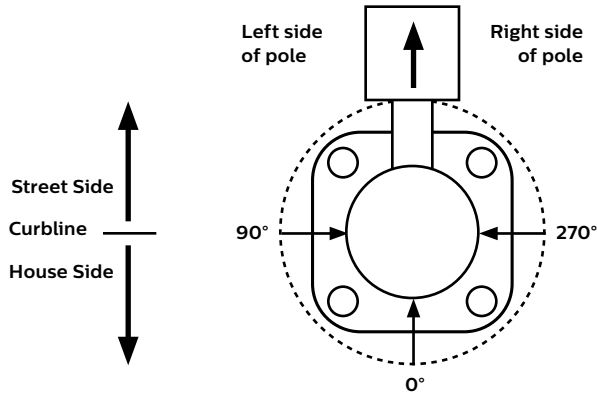

Note: The hand hole will normally be located on the pole at the 0° point.

#### Optic Rotated Left (90°) Optic Position

Luminaires ordered with optical systems in the Optic Rotated Left (90°) optic position will have the optical system oriented as shown below (Type 5 and 5W optics are not available with factory set rotatable optics):

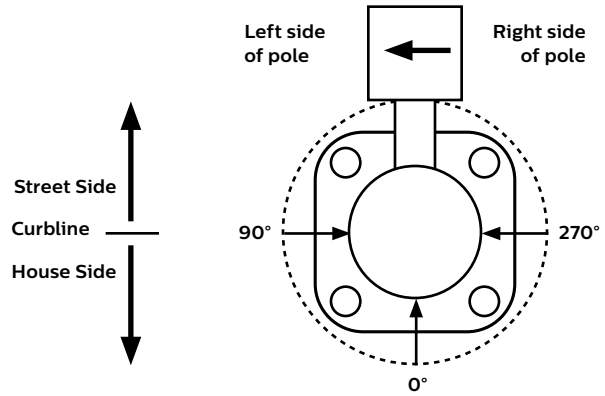

Note: The hand hole will normally be located on the pole at the 0° point.

#### Optic Rotated Right (270°) Optic Position

Luminaires ordered with optical systems in the Optic Rotated Right (270°) optic position will have the optical system oriented as shown below (Type 5 and 5W optics are not available with factory set rotatable optics):

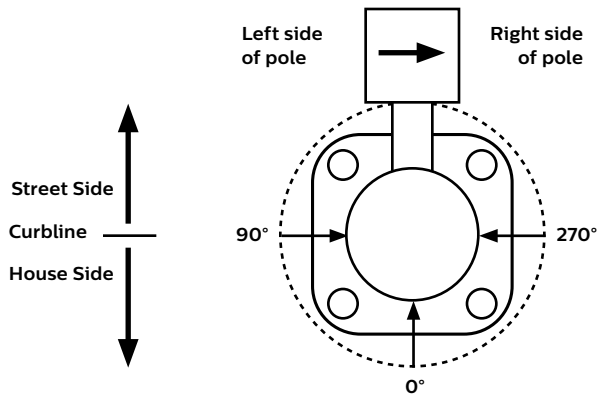

Note: The hand hole will normally be located on the pole at the 0° point.

#### Twin Luminaire Assemblies with Type-90/Type-270 Rotated Optical Systems

Twin luminaire assemblies installed with rotated optical systems are an excellent way to direct light toward the interior of the site (Street Side) without additional equipment. It is important, however, that care be exercised to insure that luminaires are installed in the proper location.

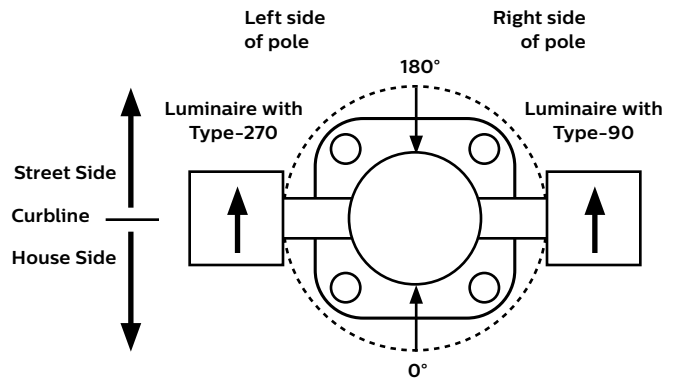

Luminaires with Optic Rotated Right (270°) are installed on the LEFT Side of Pole

Luminaires with Optic Rotated Left (90°) are installed on the RIGHT Side of Pole

Note: The hand hole location will depend on the drilling configuration ordered for the pole.

# ECF-S EcoForm small

## Area luminaire

### Specifications

#### Housing

One-piece die cast aluminum housing with integral arm and separate, self-retained hinged, one-piece die cast door frame. Luminaire housing rated to IP65, tested in accordance to Section 9 of IEC 60598-1.

#### Vibration resistance

Luminaire is tested and rated 3G over 100,000 cycles conforming to standards set forth by ANSI C136.31-2018. Testing includes vibration in three axes, all performed on the same luminaire.

#### Light engine

Light engine comprises of a module of 16-LED aluminum metal clad board fully sealed with optics offered in multiples of 2, 3, and 4 modules or 32, 48, and 64 LEDs. Module is RoHS compliant. Color temperatures: 3000K +/-125K, 4000K, 5000K +/- 200K. Minimum CRI of 70. LED light engine is rated IP66 in accordance to Section 9 of IEC 60598-1.

#### Energy saving benefits

System efficacy up to 152 lms/W with significant energy savings over Pulse Start Metal Halide luminaires. Optional control options provide added energy savings during unoccupied periods.

#### Optical systems

Type 2, 3, 4, 5, 5W, and AFR distributions available. Internal Shield option mounts to LED optics and is available with Type 2, 3, 4, and AFR distributions, including a dedicated BLC, LCL, and RCL optics to provide the best backlight control possible for those stringent requirements around property lines. Types 2, 3, 4, AFR, and BLC when specified and used as rotated, are factory set only. Performance tested per LM-79 and TM-15 (IESNA) certifying its photometric performance. Luminaire designed with 0% uplight (U0 per IESNA TM-15).

#### Mounting

Standard luminaire arm mounts to 4" O.D. round poles. Can also be used with 5" O.D. poles. Square pole adapter included with every luminaire. Round Pole Adapter (RPA) required for 3-3.9" poles. EcoForm features a retrofit arm kit. When specified with the retrofit arm (RAM) option, EcoForm seamlessly simplifies site conversions to LED by eliminating the need for additional pole drilling on most existing poles. RAM will be boxed separately. Also optional are slipfitter and wall mounting accessories. Note that only fixed mounts (AR, RAM, WS) are required to meet IDA compliance. SF mounting will not meet IDA.

#### Control options

**0-10V dimming (DD):** Access to 0-10V dimming leads supplied through back of luminaire (for secondary dimming controls by others). Cannot be used with other control options.

**Dual Circuit Control (DCC):** Luminaire equipped with the ability to have two separate circuits controlling drivers and light engines independently. Permits separate switching of separate modules controlled by use of two sets of leads, one for each circuit. Not recommended to be used with other control options, motion response, or photocells.

**Sensor Ready Zhaga Socket Connector (SRDR):** Product equipped with Sensor Ready drivers connected to 4-pin Zhaga Book 18 compliant receptacle designed for sensor and other control system applications. Receptacle is rated IP66 assembly in a compact design that provides a sealed electrical interface and rated UV resistance, mounted on underside of the luminaire, protective dust cap included. When a controller not provided by Signify is used with Sensor Ready Zhaga socket connector, the controller must be certified to work with the Xitanium SR LED drivers as part of the SR certified program. SRDR can be used with NEMA 7-pin twist lock receptacle, which is mounted on top of the luminaire.

**Automatic Profile Dimming (CS/CM/CE/CA):** Standard dimming profiles provide flexibility towards energy savings goals while optimizing light levels during specific dark hours. Dimming profiles include two dimming settings including dim to 30% or 50% of the total lumen output. When used in combination with not programmed motion response it overrides the controller's schedule when motion is detected. After 5 minutes with no motion, it will return to the automatic dimming profile schedule. Automatic dimming profile scheduled with the following settings:

- **CS50/CS30:** Security for 7 hours night duration (Ex., 11 PM - 6 AM)
- **CM50/CM30:** Median for 8 hours night duration (Ex., 10 PM - 6 AM)

All above profiles are calculated from mid point of the night. Dimming is set for 6 hours after the mid point and 1 or 2 hours before depending of the duration of dimming. Cannot be used with other dimming control options.

**Field Adjustable Wattage Selector (FAWS):** Luminaire equipped with the ability to manually adjust the wattage in the field to reduce total luminaire lumen output and light levels. Comes pre-set to the highest position at the lumen output selected. Use chart below to estimate reduction in lumen output desired. Cannot be used with other control options or motion response.

FAWS Position	Percent of Typical Lumen Output
1	25%
2	50%
3	55%
4	65%
5	75%
6	80%
7	85%
8	90%
9	95%
10	100%

**Note:** Typical value accuracy +/- 5%

**Wireless system (LLC):** Optional wireless controller integral to luminaire ready to be connected to a Lighthouse system (sold by others). The system allows you to wirelessly manage the entire site, independent lighting groups or individual luminaires while on-site or remotely. Based on a high-density mesh network with an easy to use web-based portal, you can conveniently access, monitor and manage your lighting network remotely. Wireless controls can be combined with site and area, pedestrian, and parking garage luminaires as well, for a completely connected outdoor solution. Equipped with motion response with #3 lens for 8-25' mounting heights. Also available with remote pod accessory where pod is mounted separate from luminaire to pole or wall.

#### LLC wireless controller with #3 lens

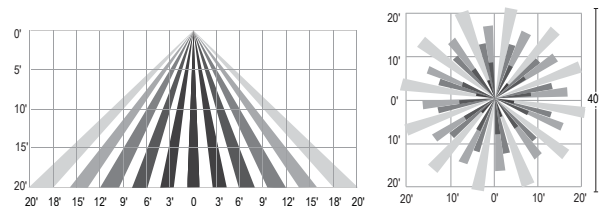

#### Motion response options

**Bi-Level Infrared Motion Response (BL-IMRI):** Motion Response module is mounted integral to luminaire factory pre-programmed to 50% dimming when not ordered with other control options. BL-IMRI is set/operates in the following fashion: The motion sensor is set to a constant 50%. When motion is detected by the PIR sensor, the luminaire returns to full power/light output. Dimming on low is factory set to 50% with 5 minutes default in "full power" prior to dimming back to low. When no motion is detected for 5 minutes, the motion response system reduces the wattage by 50%, to 50% of the normal constant wattage reducing the light level. Other dimming settings can be provided if different dimming levels are required. This can also be done with FSIR-100 Wireless Remote Programming Tool (contact Technical Support for details).

**Infrared Motion Response with Other Controls:** When used in combination with other controls (Automatic Dimming Profile), motion response device will simply override controller's schedule with the added benefits of a combined dimming profile and sensor detection. In this configuration, the motion response device cannot be re-programmed with FSIR-100 Wireless Remote Programming Tool. The profile can only be re-programmed via the controller.

# ECF-S EcoForm small

## Area luminaire

### Specifications

**Infrared Motion Response Lenses (IMRI3/IMRI7):** Infrared Motion Response Integral module is available with two different sensor lens types to accommodate various mounting heights and occupancy detection ranges. Lens #3 (IMRI3) is designed for mounting heights up to 20' with a 40' diameter coverage area. Lens #7 is designed for higher mounting heights up to 40' with larger coverage areas up to 100' diameter coverage area. See charts for approximate detection patterns:

IMRI3 Luminaire or remote mount controller with #3 lens

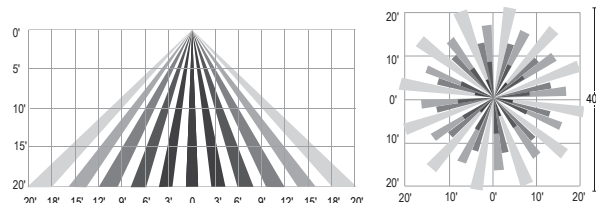

IMRI7 Luminaire or remote mount controller with #7 lens

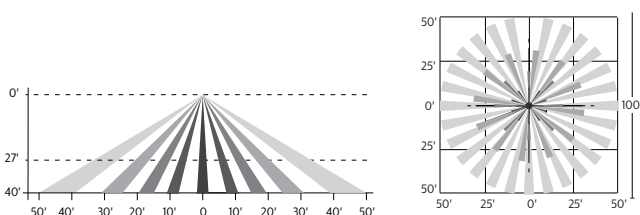

### Electrical

**Twist-Lock Receptacle (TLRD5/TLRD7/ TLRPC):** Twist Lock Receptacle with 5 pins enabling dimming or with 7 pins with additional functionality (by others) can be used with a twistlock photoelectric cell or a shorting cap. Dimming Receptacle Type B (5-pin) and Type D-24 (7-pin) in accordance to ANSI C136.41. Can be used with third-party control system. Receptacle located on top of luminaire housing. When specifying receptacle with twistlock photoelectric cell, voltage must be specified. When ordering 7-pin Twist-lock receptacle (TLRD7), all 7 pins are wired to respective pins with the Sensor Ready (SR) driver, and photocell or shorting cap is not included. When ordering a twist-lock receptacle with a photocell (TLRPC), the receptacle used is a 5-pin receptacle, so pins 6 and 7 are not available (no SR driver). 0-10V dimming leads (pins 4 and 5) are connected if not ordered with any other dimming option.

### Buy American Act of 1933 (BAA):

This product is manufactured in one of our US factories and, as of the date of this document, this product was considered a commercially available off-the-shelf (COTS) item meeting the requirements of the BAA. This BAA designation hereunder does not address (i) the applicability of, or availability of a waiver under, the Trade Agreements Act, or (ii) the "Buy America" domestic content requirements imposed on states, localities, and other non-federal entities as a condition of receiving funds administered by the Department of Transportation or other federal agencies. Prior to ordering, please visit [www.signify.com/baa](http://www.signify.com/baa) to view a current list of BAA-compliant products to confirm this product's current compliance.

**Driver:** Driver efficiency (>90% standard). 120-480V available (restrictions apply). Open/short circuit protection. All drivers are 0-10V dimming to 10% power standard, except when using Sensor Ready (SR) drivers, which uses DALI protocol (options CS50/CM50/CS30/CM30, SRDR, and TR7). Drivers are RoHS and FCC Title 47 CFR Part 15 compliant.

**Button Photocontrol (PCB):** Button style design for internal luminaires mounting applications. The photocontrol is constructed of a high impact UV stabilized polycarbonate housing. Rated voltage of 120V or 208-277V with a load rating of 1000 VA. The photocell will turn on with 1-4Fc of ambient light.

**Surge protection (SP1/SP2):** Surge protection device tested in accordance with ANSI/IEEE C62.45 per ANSI/IEEE C62.41.2 Scenario I Category C High Exposure 10kV/10kA waveforms for Line-Ground, Line-Neutral and Neutral-Ground, and in accordance with DOE MSSLC Model Specification for LED Roadway Luminaires Appendix D Electrical Immunity High test level 10kV/10kA, 20kV / 10kA surge protection device that provides extra protection beyond the SP1 10kV/10kA level.

### Listings

UL/cUL wet location listed to the UL 1598 standard, suitable for use in ambient temperatures from -40° to 40°C (-40° to 104°F). Most EcoForm configurations are qualified under Premium and Standard DesignLights Consortium® categories. Consult DLC Qualified Products list to confirm your specific luminaire selection is approved. CCTs 3000K and warmer are Dark Sky Approved.

### Finish

Each standard color luminaire receives a fade and abrasion resistant, electrostatically applied, thermally cured, triglycidal isocyanurate (TGIC) textured polyester powdercoat finish. Standard colors include bronze (BZ), black (BK), white (WH), dark gray (DGY), and medium gray (MGY). Consult factory for specs on optional or custom colors.

### Service Tag

Each individual luminaire is uniquely identifiable, thanks to the Service tag application. With a simple scan of a QR code, placed on the inside of the mast door, you gain instant access to the luminaire configuration, making installation and maintenance operations faster and easier, no matter what stage of the luminaire's lifetime. Just download the APP and register your product right away. For more details visit: [signify.com](http://signify.com)

### Warranty

EcoForm luminaires feature a 5-year limited warranty. See [signify.com/warranties](http://signify.com/warranties) for complete details and exclusions.



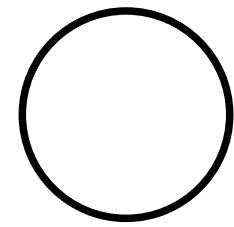

The Gardco TRA Tapered Round Aluminum pole consists of a one-piece design fabricated aluminum tubing circumferentially welded to a structural quality hot rolled carbon steel plate. The poles are finished with either Architectural Class 1 anodizing or electrostatically applied TGIC polyester powdercoat.

Project: \_\_\_\_\_  
 Location: \_\_\_\_\_  
 Cat.No: \_\_\_\_\_  
 Type: \_\_\_\_\_  
 Notes: \_\_\_\_\_

### Ordering Guide

example: TRA-CB-16L-D2-BRP

Prefix	Base	Height	Wind Factor	Drilling <sup>1</sup>	Finish	Options
<b>TRA</b>						
TRA	CB	8 10 12 14 16 25 28 30 35	- - L	D1 1 Way D2 2 Way at 180° D2@90 2 Way at 90° D3 3 Way at 90° D3@120 3 Way at 120° D4 4 Way T2 2.4" OD Tenon X 4" long T3 3" OD Tenon X 4" long T4 4" OD Tenon X 6" long P Plain Top (No Drilling/No Tenon)	BRP Bronze BLP Black WP White MGY Medium Grey DGY Dark Grey BRA Bronze Anodized BLA Black Anodized NA Natural Anodized OC Optional Color (Specify RAL designation ex: RAL7024) SC Special Color (Specify. Must supply color chip.)	DR Duplex Receptacle GFCI Ground Fault Receptacle VDA Vibration Dampener AHH Additional Hand Hole  For DR, GFCI, and AHH options indicate height above base and orientation to original hand hole. See Pole Orientation Information on Page 5.  <b>Nipples and Couplings</b> CL1/2 Coupling - Internal Thread 1/2" CL3/4 Coupling - Internal Thread 3/4" CL1 Coupling - Internal Thread 1" CL1-1/4 Coupling - Internal Thread 1-1/4" CL1-1/2 Coupling - Internal Thread 1-1/2" NL1/2 Nipple - External Thread 1/2" NL3/4 Nipple - External Thread 3/4" NL1 Nipple - External Thread 1" NL1-1/4 Nipple - External Thread 1-1/4" NL1-1/2 Nipple - External Thread 1-1/2"  Indicate height above base and orientation to hand hole. See Pole Orientation Information on Page 5.  <b>Single Mount Bullhorn Brackets</b> A15BH-19 Single - 1.9" OD <sup>2</sup> A15BH-24 Single - 2.4" OD A215BH-19 2-Tenon - 1.9" OD <sup>2</sup> A215BH-24 2-Tenon - 2.4" OD  Indicate height above base and orientation to hand hole. See Pole Orientation Information on Page 4.  Additional and alternative brackets and accessories available. Refer to the Signify product catalog (eCat) website for more information.
		12 14 16 20	M			
		20 25 28 30 35 39	H			

- Standard poles are drilled in factory for compatibility with Signify luminaires only (D\* options). For non-Signify-brand luminaires, select the P drilling option.
- For Gardco DFL7/DFC7 only

### Anchor Bolts for Gardco TRA Poles<sup>3</sup> (ordered separately)

	Pole Type	12NC for ordering	Description (in inches)
For Pre-ship service (Order 4 per pole)	8 to 25L	912400215786	0.75 x 18 x 3.75
	25H to 39H	912400215784	1 x 36 x 4.5
For shipment with the pole (Order 1 per pole)	8 to 25L	912400207384	0.75 x 18 x 3.75
	25H to 39H	912400200208	1 x 36 x 4.5

- Consult Signify to confirm whether specific accessories are BAA-compliant.



# Poles Tapered Round Aluminum (Cast Base)

## Pole Data

Product Catalog Number	Pole Specs				Anchor Bolt Data <sup>2</sup>		
	Height (ft)	Pole Diameter (inches)	Wall Thickness (inches)	Structure Weight (lbs)	Bolt Circle (inches)	Bolt Size (inches)	Max Proj. (inches)
TRA-CB-8	7' 8"	3 x 4	0.125	17	7.50 (+/- 0.75)	0.75 x 18 x 3.75	3.25
TRA-CB-10	9' 8"	3 x 4	0.125	20	7.50 (+/- 0.75)	0.75 x 18 x 3.75	3.25
TRA-CB-12L	11' 8"	3 x 4	0.125	23	7.50 (+/- 0.75)	0.75 x 18 x 3.75	3.25
TRA-CB-12M	11' 8"	3 x 5	0.125	26	8.63 (+/- 0.88)	0.75 x 18 x 3.75	3.25
TRA-CB-14L	13' 8"	3 x 4	0.125	27	7.50 (+/- 0.75)	0.75 x 18 x 3.75	3.25
TRA-CB-14M	13' 8"	3 x 5	0.125	31	8.63 (+/- 0.88)	0.75 x 18 x 3.75	3.25
TRA-CB-16L	15' 8"	3 x 5	0.125	30	8.63 (+/- 0.88)	0.75 x 18 x 3.75	3.25
TRA-CB-16M	15' 8"	3 x 5	0.188	35	8.63 (+/- 0.88)	0.75 x 18 x 3.75	3.25
TRA-CB-20M	19' 8"	3 x 5	0.156	51	8.63 (+/- 0.88)	0.75 x 18 x 3.75	3.25
TRA-CB-20H	19' 8"	3 x 5	0.188	60	8.63 (+/- 0.88)	0.75 x 18 x 3.75	3.25
TRA-CB-25L <sup>3</sup>	24' 8"	4 x 6	0.156	74	8.63 (+/- 0.88)	0.75 x 18 x 3.75	3.50
TRA-CB-25H	24' 8"	4 x 7	0.156	85	9.50 (+/- 0.75)	1 x 36 x 4.5	4.13
TRA-CB-28L <sup>3</sup>	27' 8"	4 x 7	0.156	92	10.56 (+/- 0.43)	1 x 36 x 4.5	4.13
TRA-CB-28H	27' 8"	4.5 x 8	0.188	124	10.56 (+/- 0.43)	1 x 36 x 4.5	4.13
TRA-CB-30L <sup>3</sup>	29' 8"	4 x 7	0.156	99	11.63 (+/- 0.37)	1 x 36 x 4.5	4.13
TRA-CB-30H	29' 8"	4.5 x 8	0.188	134	10.56 (+/- 0.43)	1 x 36 x 4.5	4.13
TRA-CB-35L <sup>3</sup>	34' 8"	4.5 x 8	0.156	133	11.63 (+/- 0.37)	1 x 36 x 4.5	4.13
TRA-CB-35H	34' 8"	4.5 x 8	0.25	205	11.63 (+/- 0.37)	1 x 36 x 4.5	4.13
TRA-CB-39L <sup>3</sup>	38' 8"	4.5 x 8	0.188	179	11.63 (+/- 0.37)	1 x 36 x 4.5	4.13
TRA-CB-39H	38' 8"	6 x 10	0.188	232	14.25 (+/- 0.75)	1 x 36 x 4.5	4.75

- Warning:** Additional wind loading, in terms of EPA, from banners, cameras, floodlights and other accessories attached to the pole, must be added to the luminaire(s) EPA before selecting the pole with the appropriate wind load capability.
- Factory supplied template must be used when setting anchor bolts. Gardco will not honor any claim for incorrect anchorage placement resulting from failure to use factory supplied templates.
- Includes (VDA) Vibration Dampener standard.

# Poles Tapered Round Aluminum (Cast Base)

## Pole Data

Catalog Number	Maximum Luminaire Loading <sup>1</sup>							
	High Wind Conditions		Normal Wind Conditions					
	110 MPH		100 MPH		90 MPH		80 MPH	
Prefix	EPA ft <sup>2</sup>	Max Weight (lbs)	EPA ft <sup>2</sup>	Max Weight (lbs)	EPA ft <sup>2</sup>	Max Weight (lbs)	EPA ft <sup>2</sup>	Max Weight (lbs)
TRA-CB-8	4.1	75	5.1	75	6.5	75	8.5	75
TRA-CB-10	2.9	75	3.7	75	4.8	75	6.4	75
TRA-CB-12L	1.9	75	2.6	75	3.5	75	4.8	75
TRA-CB-12M	4.6	75	5.8	75	7.4	75	9.8	75
TRA-CB-14L	1.1	75	1.6	75	2.4	75	3.5	75
TRA-CB-14M	3.4	75	4.4	75	5.8	75	7.8	75
TRA-CB-16L	0.4	75	0.8	75	1.5	75	2.4	75
TRA-CB-16M	2.4	75	3.2	75	4.3	75	6.0	75
TRA-CB-20M	1.5	100	2.2	100	3.2	100	4.7	100
TRA-CB-20H	2.3	100	3.1	100	4.3	100	6.1	100
TRA-CB-25L <sup>3</sup>	1.9	100	2.5	100	3.5	100	5.1	100
TRA-CB-25H	4.2	150	5.3	150	7.0	150	9.6	150
TRA-CB-28L <sup>3</sup>	2.8	150	3.7	150	5.0	150	7.1	150
TRA-CB-28H	6.8	150	8.5	150	10.8	150	14.3	150
TRA-CB-30L <sup>3</sup>	2.0	150	2.7	150	3.8	150	5.7	150
TRA-CB-30H	5.6	150	7.1	150	9.2	150	12.2	150
TRA-CB-35L <sup>3</sup>	2.1	150	2.9	150	4.0	150	5.7	150
TRA-CB-35H	5.8	150	7.3	150	9.5	150	12.7	150
TRA-CB-39L <sup>3</sup>	1.9	150	2.8	150	3.9	150	5.6	150
TRA-CB-39H	5.8	200	7.7	200	10.2	200	13.6	200

- Warning:** Additional wind loading, in terms of EPA, from banners, cameras, floodlights and other accessories attached to the pole, must be added to the luminaire(s) EPA before selecting the pole with the appropriate wind load capability.
- Factory supplied template must be used when setting anchor bolts. Gardco will not honor any claim for incorrect anchorage placement resulting from failure to use factory supplied templates.
- Includes (VDA) Vibration Dampener standard.

## Dimensions

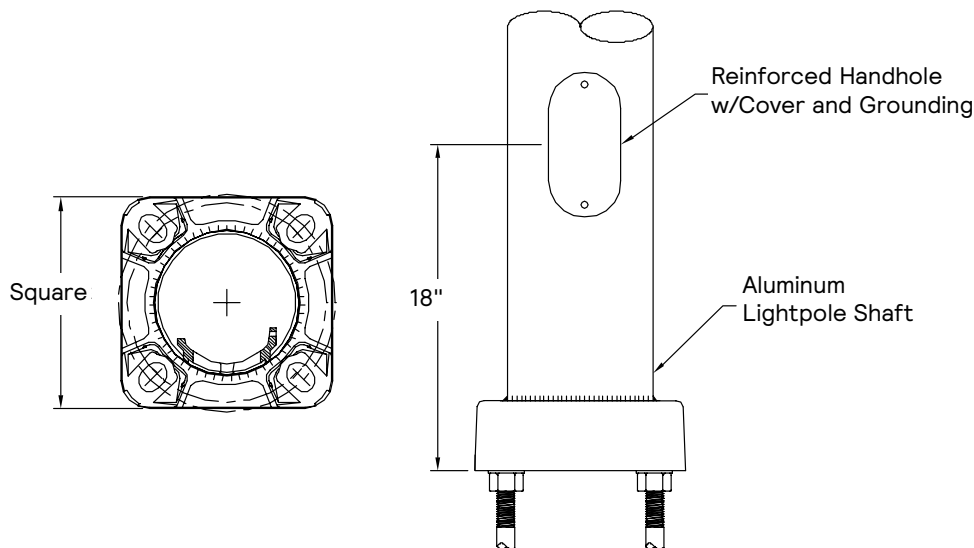

**NOTE:** Factory supplied template must be used when setting anchor bolts. Gardco will not honor any claim for incorrect anchorage placement from failure to use factory supplied templates.

# Poles Tapered Round Aluminum (Cast Base)

## Specifications

All aluminum alloys shall comply with metalurgical and mechanical properties set forth in the Aluminum Association Standards.

### POLE SHAFT

The pole shaft shall be spun tapered from all new seamless 6063 alloy aluminum and shall be heat treated to produce a T6 temper. Each shaft shall have a minimum 6" long straight section at the top to accommodate drilling and/or Gardco floodlight and bullhorn brackets. Shafts are polished with fine grain aluminum oxide cloths, resulting in a high quality, circumferential satin brushed finish. After finishing, each pole shall be fully wrapped with neutral PH kinkle/kraft paper for protection in shipment.

### ANCHOR BASE

The anchor base (base plate) is cast from A356 alloy aluminum. The anchor base casting and shaft shall be joined by a continuous circumferential weld at the inside bottom of the anchor base. The completed assembly will be heat treated to T6 temper after all structural welding is completed. The 1100-0 alloy collars are spun from heavy duty .125" stock, making them damage and vandal resistant.

### ANCHOR BOLTS

Anchor bolts are fabricated from a commercial quality hot rolled carbon steel bar with a minimum yield strength of 55,000 PSI. Bolts have an "L" bend on one end and threaded on the opposite end. Anchor bolts are hot dipped galvanized a minimum length of 12" on the threaded end. Four (4) properly sized bolts, each furnished with two (2) regular hex nuts and two (2) flat washers, are provided per pole (priced separately), unless otherwise specified.

### HAND HOLE

Each hand hole includes an easy to install, self-contained Swing Latch hand hole cover assembly. U.S. Patent Swing Latch cover is fabricated from durable polycarbonate/ABS blend plastic. All poles include a peripherally reinforced flush covered handhole centered 18" above the bottom of the pole. The opening in the 4" diameter pole shall measure 2 3/8" X 4 1/2". The opening in the 5" and 6" diameter pole shall measure 3" X 5". The opening in the 7", 8" and 10" diameter pole shall measure 4" X 6". Hand hole dimensions are nominal.

### DRILLING

Standard poles are drilled in factory for compatibility with Signify luminaires, optional brackets, and accessories. Signify is not liable for damage caused by unauthorized attachments, alterations, or modifications.

If luminaires are to be supplied by others, Signify/Gardco/Stonco is not responsible for pole compatibility with luminaires, structural integrity of the pole or wind load requirements.

### FINISH

Poles are available with Association Architectural Class 1 anodized finish. Electrostatically applied, thermally cured TGIC polyester powdercoat finish or liquid polyurethane is also available.

### POLE TOP CAP

Each pole assembly is provided with a removable plastic top push cap. Finish is Black.

### DESIGN

The charted weights include luminaire(s) and/or mounting bracket(s) and are based on an approximate weight to EPA ratio of 25 pounds per square foot. The wind velocities are based on 10 mph increments from 80 mph through 110 mph. Poles to be located in areas of known abnormal conditions may require special consideration.

For example: coastal areas, airports and areas of special winds.

Poles are designed for ground-mounted applications. Poles mounted on structures (such as buildings and bridges) may also necessitate special consideration requiring Gardco's recommendation. Height correction factors and drag coefficients are applied to the entire structure. An appropriate safety factor is maintained based on the minimum yield strength of the material incorporated in the pole. Mounting height is the vertical distance from the base of the pole to the center of the luminaire arm at the point of luminaire attachment. For loadings other than those covered in the design section, such as overhead wiring, guying of the poles or other field installed attachments, consult the factory for recommendations. PE digitally stamped pole calculations are available on Gardco Site and Area poles upon request for an additional charge. Detailed project and installation information is required to fulfill this service. For more information, consult the factory.

### WARNING

This design information is intended as a general guideline only. The customer is solely responsible for proper selection of pole, luminaire, accessory and foundation under the given site conditions and intended usage. The addition of any items to the pole, in addition to the luminaire, will dramatically impact the EPA load on that pole. It is strongly recommended that a qualified professional be consulted to analyze the loads given the user's specific needs to ensure proper selection of the pole, luminaire, accessories, and foundation. Gardco assumes no responsibility for such proper analysis or product selections. Failure to insure proper site analysis, pole selection, loads and installation can result in pole failure, leading to serious injury or property damage.

### WARRANTY

Gardco poles feature a 1 year limited warranty. See Warranty Information on [www.signify.com/warranties](http://www.signify.com/warranties) for complete details and exclusions.

# Poles Straight Square Steel

## Orientation Information

Factory installed options and accessories

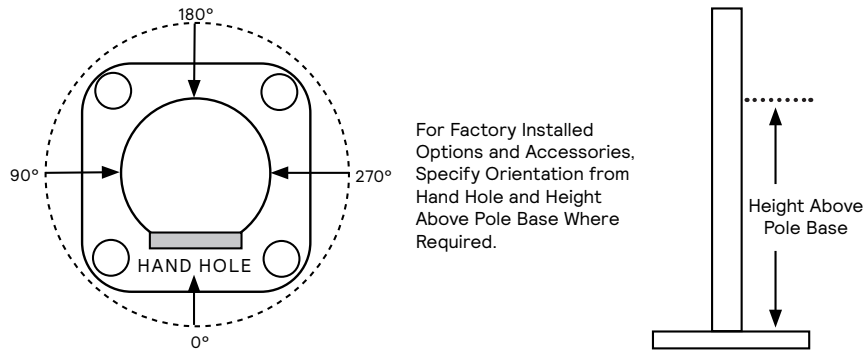

Orientation is measured clockwise from the Hand Hole Center.

## Standard arm mount luminaire orientation

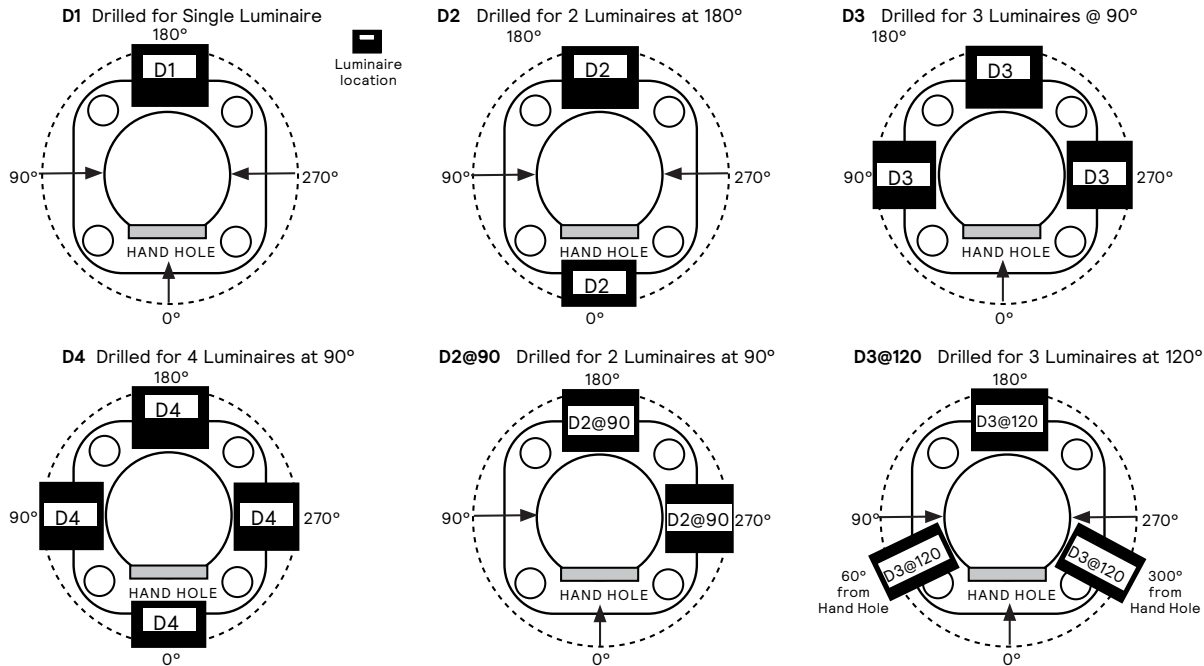

## Buy American Act of 1933 (BAA):

This product is manufactured in one of our US factories and, as of the date of this document, this product was considered a commercially available off-the-shelf (COTS) item meeting the requirements of the BAA. This BAA designation hereunder does not address (i) the applicability of, or availability of a waiver under, the Trade Agreements Act, or (ii) the "Buy America" domestic content requirements imposed on states, localities, and other non-federal entities as a condition of receiving funds administered by the Department of Transportation or other federal agencies. Prior to ordering, please visit [www.signify.com/baa](http://www.signify.com/baa) to view a current list of BAA-compliant products to confirm this product's current compliance.





**TOWN OF RICHMOND**  
**RICHMOND TOWN CENTER**  
203 Bridge Street, P.O. Box 285  
Richmond, Vermont 05477



March 21, 2023

Jameson Partners LLC  
22 Depot St.  
Richmond, VT 05477

RE: Preliminary Water & Sewer Allocation for DS0022

Dear Derick Read,

This letter is in response to your request to increase the water and sewer allocation at DS0022. Your request was outlined as follows in water service allocation forms dated 2/28/23:

- 4 new 2 bedroom dwellings and two first floor commercial spaces with 8 total employees
- 960 gallons of water per day requested to meet the demands of the proposed development
- 960 gallons of wastewater per day requested to meet the demands of the proposed development

We have checked these figures with our Town engineer and concur with your calculations.

This information was presented to the Water and Sewer Commission at their meeting on 3/13/23. At that meeting the Commission voted to approve preliminary allocation as outlined above. The Commission conditioned the approval on the building's stormwater being disconnected from the sewer system. Enclosed, please find the approved water and sewer allocation requests.

In order to proceed to final allocation the Town must be in receipt of payment for the increase allocation. Charges are as follows:

- Additional Water Allocation of 960 gpd @ \$1.89 per gallon: \$1,814.40
- Additional Sewer Allocation of 960 gpd @ \$4.41 per gallon: \$4,233.60
- Total combined due for Water and Sewer Allocations: \$6,048.00

You have 60 days from preliminary allocation to proceed to a request for final allocation. I will need a check for the total amount due prior to the meeting at which you would like to be considered for final allocation. The allocations are not final until they are approved by the Water and Sewer Commission and final payment is received. Construction cannot start until final allocations are paid for and approved.

Please contact me to let me know when you would like to proceed with final allocation approval.

Sincerely,

A handwritten signature in black ink, appearing to read "Josh Arneson", with a long horizontal flourish extending to the right.

Josh Arneson  
Town Manager

CC: Interim Water and Sewer Superintendent Allen Carpenter  
Zoning Administrative Officer Tyler Machia  
Town Clerk Linda Parent  
Finance Director Connie Bona

# Stormwater Narrative

## 22 Depot Street

### Richmond, Vermont

#### **Project Description**

Jameson Partners LLC is proposing an addition to the existing structure at 22 Depot Street. The existing building is currently occupied by the Giffords Mortuary on the first floor and two residential units on the upper level. The project will expand the west side of the building to include two commercial or retail spaces on the lowest level and 4 new residential dwellings on the second and third floors. The project will add 12 new parking spaces at the back of the building to displace the existing parking and provide a space for each unit.

The project will include 0.07 acres of expanded impervious and 0.10 acres of redevelopment impervious.

#### **Stormwater Strategy**

The project is below the State of Vermont stormwater jurisdiction for an operational permit. Therefore, the stormwater management design focused on compliance with the Town of Richmond Zoning Regulations Section 6.1.6(c) Drainage. The project is required to maintain the post development peak discharge rates of the 25 year, 24 hour storm below the pre-development peak discharge rates for the same storm event.

The site is mapped by the USDA Natural Resources Conservation Service to include infiltrative soils so we performed a test hole and permeability test. The soil investigation proved the mapping to be correct as shown in the testing results provided on plan sheet WS-Post. The stormwater system has been designed to rely on the deep layer of well drain coarse sand. An underground stormwater infiltration chamber system has been designed to capture and infiltrate the 10 year, 24 hour storm event for the drainage area on the parcel. Plan sheet WS-Post shows the drainage area for watershed WS-P2 that is collected by the practice. This includes the new parking lot behind the building, the re-directed roof runoff from the existing building, and the northeastern half of the new building. By infiltrating the 10 year storm the project will reduce the post development peak runoff for the 25 year storm. The hydrologic modeling for the 25 year storm event, calculations, and plans are attached for review.





**Project Name:** 22 Depot Street

**Discharge Point:** 1

**Infiltration Practice #** 1

**Infiltration (4.3.3)**

	Practice Drainage Area	For Permit Coverage	Not for Permit Coverage	Total to Practice
1	Total Area (acres)	0.112	0.000	0.112
2	New Impervious (acres)	0.060	0.000	0.060
3	Redeveloped Impervious	0.093	0.000	0.093
		WQ <sub>V</sub> for credit	WQ <sub>V</sub> not for credit	Total WQ <sub>V</sub>
4	WQ <sub>V</sub> to practice	0.0087	0.0000	0.0087

Modified CN for WQ<sub>V</sub> (1.0") storm: 99

5 Design Volume for Infiltration (T<sub>V</sub>): 0.0000 ← T<sub>V</sub> value to enter on the Standards Compliance Workbook for this practice

6 Practice Type

- Infiltration Basin
- Infiltration Trench
- Infiltration Chambers
- Drywell(s)

Note: If the practice is designed to infiltrate the WQ<sub>V</sub>, then T<sub>V</sub> = WQ<sub>V</sub>. Designers may use the Practice Drainage Area Runoff Calculator (second tab) for calculation of practice-specific runoff volumes for other treatment standards. Sizing of the filter bed area/swale bottom need to consider the desired treatment volume (see treatment section). Some design requirements will change based on the size of storm the practice is designed to treat.

\* Questions preceded by an asterisk (\*) may change based on previously entered values

**Feasibility (4.3.3.1)**

	Response	Attachment location
7	Has the infiltration rate (fc) of the underlying soil been confirmed to be at least 0.2 inches per hour by the soil testing requirements in Section 4.3.3.2?	<input type="radio"/> Yes <input type="radio"/> No
8*	Is the seasonal high groundwater table (SHGWT) separated at least three (3) feet vertically from the bottom of the practice?	<input type="radio"/> Yes <input type="radio"/> No
9	Has a groundwater mounding analysis been performed if the practice is designed to infiltrate >1 year storm and the SHGWT <4 feet?	<input type="radio"/> Yes <input type="radio"/> No
10	Have the proper setback requirements for groundwater source protection been observed? (Section 4.3.3.1)	<input type="radio"/> Yes <input type="radio"/> No
11	Has the practice been placed so that it will not cause intrusion problems for down-gradient structures? (Section 4.3.3.1)	<input type="radio"/> Yes <input type="radio"/> No
12	Is the site free from subsurface contamination or prior approval obtained from the Agency? (If approval is required based on prior contamination, include	<input type="radio"/> Yes <input type="radio"/> No
13*		<input type="radio"/> Yes <input type="radio"/> No

**Conveyance (4.3.3.2)**

Response	Attachment location
----------	---------------------

14	Have the outfalls and the conveyance to the discharge point been designed/protected to avoid erosive velocities?	<input type="radio"/> Yes <input type="radio"/> No	
15	Is the practice designed to completely dewater the treatment volume ( $T_V$ ) within 48 hours after the storm event?	<input type="radio"/> Yes <input type="radio"/> No	
16	If the practice is designed to infiltrate <1 year storm and runoff is delivered by the main conveyance system, has it been designed as an off-line practice?	<input type="radio"/> Yes <input type="radio"/> No	

<b>Pre-Treatment (4.3.3.3)</b>		<b>Response</b>	<b>Attachment location</b>
17	Has pretreatment been provided for non-rooftop runoff?	<input type="radio"/> Yes <input type="radio"/> No	
18	What type of pretreatment is being used? <input type="checkbox"/> Swale <input checked="" type="checkbox"/> Forebay <input type="checkbox"/> Proprietary <input type="checkbox"/> Filter Strip <input type="checkbox"/> Deep Sump Catch Basins		
19*	Is the infiltration rate ( $f_c$ ) greater than or less than 2 inches per hour?	<input type="radio"/> $\leq 2$ in/hr <input type="radio"/> $> 2$ in/hr	
20*	Is the forebay sized to hold at least 50% of the WQv?	<input type="radio"/> Yes <input type="radio"/> No	
21*	Is the forebay separated at least three (3) feet from the SHGWT or located over impermeable soils?	<input type="radio"/> Yes <input type="radio"/> No	

<b>Treatment (4.3.2.4)</b>		<b>Response</b>	<b>Attachment location</b>
22	Has direct access been provided to the practice for maintenance and rehabilitation?	<input type="radio"/> Yes <input type="radio"/> No	
23*	Has an observation well been installed in every trench, drywell, or subsurface system?	<input type="radio"/> Yes <input type="radio"/> No	
24	What is the physical storage volume up to the overflow? (ac-ft)		Enter this on the eNOI
25	What is the treatment volume provided by the STP? $T_V$ (ac-ft)		

Treatment Volume ( $T_V$ ) for infiltration practices may be calculated using the equations provided as design guidance in Section 4.3.3.5 OR by demonstrating infiltration of the  $T_V$  using TR-20 or an approved equivalent.

<b>Landscaping (4.3.2.5)</b>		<b>Response</b>	<b>Attachment location</b>
26	Does the site plan specify a landscaping plan that ensures dense and vigorous vegetation over the contributing pervious drainage areas and the practice?	<input type="radio"/> Yes <input type="radio"/> No	

**Attachment location:** Indicate the specific location (i.e. appendix, page, plan sheet) where the requisite support documentation has been provided within the application.

**Practice Drainage Area Runoff Calculator**

Project Name: 22 Depot Street Total WS

Discharge Point: 1

Infiltration Practice # 1

This tool may be used to calculate the required treatment volumes for the area draining to an individual practice where the practices drainage area is only a portion of of the area draining to a discharge point. Where the practice receives runoff from the entire area to a discharge point, this calculator will give the same information as the Standards Compliance Workbook.

**Precipitation Data**

\* Precipitation values shall be obtained from [NOAA Atlas 14](#)

Storm	WQ Storm	1 yr, 24 hr	10 yr, 24 hr	100 yr, 24 hr
Precipitation (inches)	1.00	1.98	3.49	5.28

**Drainage Area Information**

Pre Development Land Use (acres)

Landuse	Hydrologic Soil Group				Total (acres)
	A	B	C	D	
Grass	0.107	0.000	0.000	0.000	0.107
Meadow	0.000	0.000	0.000	0.000	0.000
Woods	0.000	0.000	0.000	0.000	0.000
Pavement, roofs, and other impervious	0.166	0.000	0.000	0.000	0.166
<b>Total</b>	<b>0.273</b>	<b>0.000</b>	<b>0.000</b>	<b>0.000</b>	<b>0.273</b>

Post Development Land Use (acres)

Landuse	Hydrologic Soil Group				Total (acres)
	A	B	C	D	
Grass	0.056	0.000	0.000	0.000	0.056
Meadow	0.000	0.000	0.000	0.000	0.000
Woods	0.000	0.000	0.000	0.000	0.000
Pavement, roofs, and other impervious	0.217	0.000	0.000	0.000	0.217
<b>Total</b>	<b>0.273</b>	<b>0.000</b>	<b>0.000</b>	<b>0.000</b>	<b>0.273</b>

T<sub>v</sub> of upstream practices: 0.000 ac-ft

T<sub>v</sub> credit of this practice: 0.000 ac-ft

Treatment Standard	Required Treatment Volume	Post Development Runoff Volume	Pre-development Runoff Volume	Post Composite CN (to practice)	CN <sub>Adj</sub> (with T <sub>v</sub> practice credit)	Pre Composite CN
Channel Protection (Hydrologic Condition Method)	0.0075	0.0317	0.0243	94	94	90
Overbank Flood	0.0138	0.0589	0.0451	92	92	85
Extreme Flood	0.0203	0.0924	0.0721	89	89	80

**Information for Calculating T<sub>c</sub> by the Watershed Lag Method**

Average Catchment	Hydraulic	Time of Concentration, T <sub>c</sub> (min)
-------------------	-----------	---

	Slope, Y (%)	Length, l (ft)	1 yr	10 yr	100 yr
Pre Development	5.50%	181.00	2.4	3.0	3.4
Post Development, upstream of practice	5.50%	94.00	1.2	1.3	1.5
Post Development, with T <sub>v</sub> credit from practice	0.00%	0.00	0.0	0.0	0.0

22 Depot Street, Richmond

25YR Storm Post

25YR Storm Pre

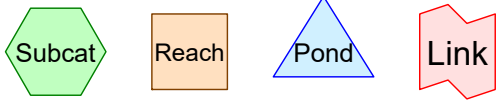
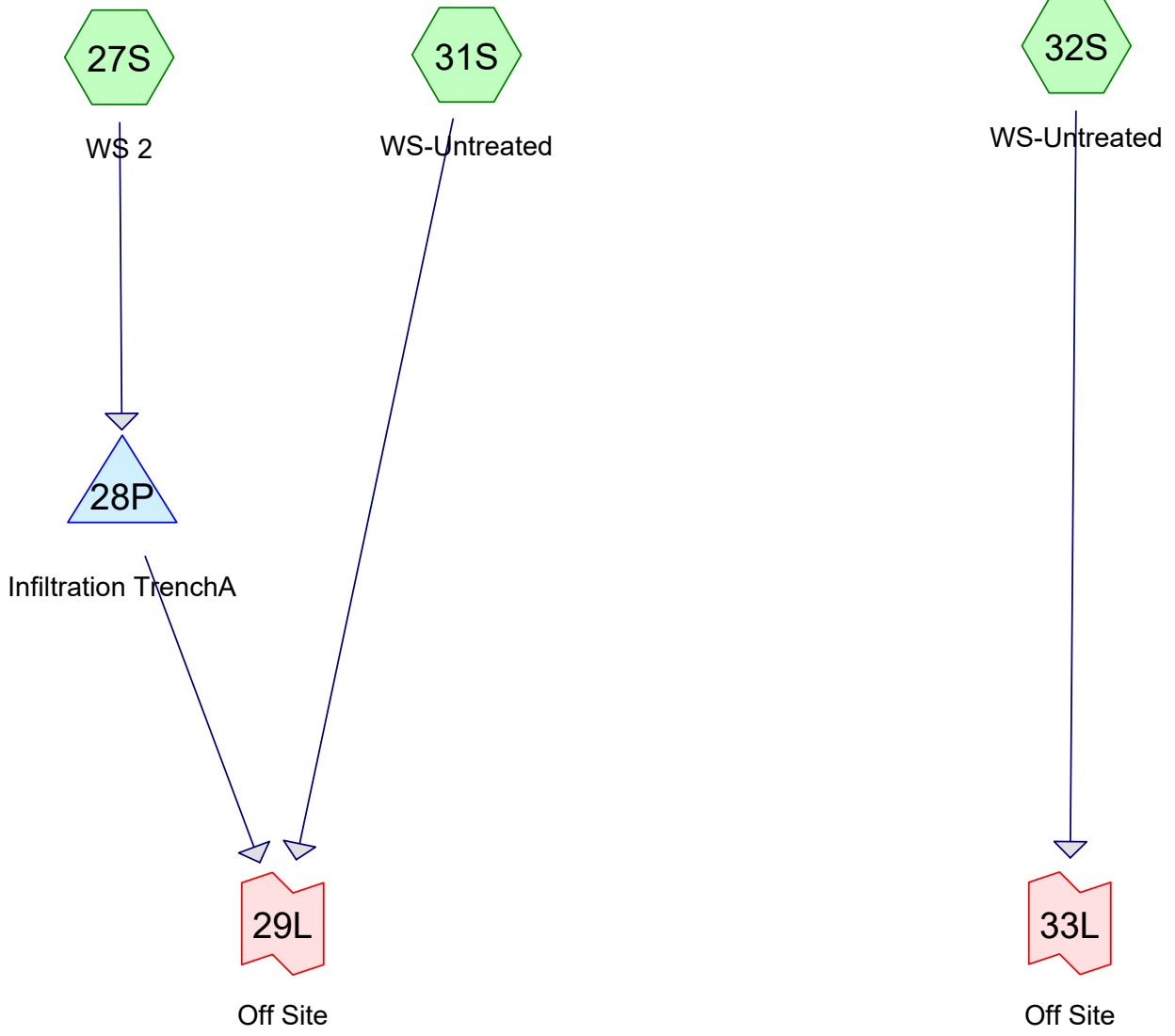

## 22 Depot Storm

Prepared by Krebs & Lansing Consulting Engineers, Inc.

HydroCAD® 10.00 s/n 06429 © 2013 HydroCAD Software Solutions LLC

Printed 3/20/2023

Page 3

### Area Listing (selected nodes)

Area (acres)	CN	Description (subcatchment-numbers)
0.208	95	Worksheet (27S)
0.338	90	Worksheet (31S, 32S)
<b>0.546</b>	<b>92</b>	<b>TOTAL AREA</b>

## 22 Depot Storm

Type II 24-hr 25 Year Rainfall=4.19"

Prepared by Krebs & Lansing Consulting Engineers, Inc.

Printed 3/20/2023

HydroCAD® 10.00 s/n 06429 © 2013 HydroCAD Software Solutions LLC

Page 4

Time span=0.00-72.00 hrs, dt=0.01 hrs, 7201 points  
Runoff by SCS TR-20 method, UH=SCS, Weighted-Q  
Reach routing by Stor-Ind+Trans method - Pond routing by Stor-Ind method

<b>Subcatchment27S: WS 2</b>	Runoff Area=0.208 ac 0.00% Impervious Runoff Depth=3.62" Tc=1.1 min CN=95 Runoff=1.39 cfs 0.063 af
<b>Subcatchment31S: WS-Untreated</b>	Runoff Area=0.065 ac 0.00% Impervious Runoff Depth=3.10" Tc=1.5 min CN=90 Runoff=0.39 cfs 0.017 af
<b>Subcatchment32S: WS-Untreated</b>	Runoff Area=0.273 ac 0.00% Impervious Runoff Depth=3.10" Tc=3.1 min CN=90 Runoff=1.57 cfs 0.071 af
<b>Pond 28P: Infiltration TrenchA</b>	Peak Elev=329.56' Storage=926 cf Inflow=1.39 cfs 0.063 af Discarded=0.07 cfs 0.058 af Primary=0.95 cfs 0.005 af Outflow=1.02 cfs 0.063 af
<b>Link 29L: Off Site</b>	Inflow=1.22 cfs 0.022 af Primary=1.22 cfs 0.022 af
<b>Link 33L: Off Site</b>	Inflow=1.57 cfs 0.071 af Primary=1.57 cfs 0.071 af

**Total Runoff Area = 0.546 ac Runoff Volume = 0.150 af Average Runoff Depth = 3.30"**  
**100.00% Pervious = 0.546 ac 0.00% Impervious = 0.000 ac**

# 22 Depot Storm

Prepared by Krebs & Lansing Consulting Engineers, Inc.

HydroCAD® 10.00 s/n 06429 © 2013 HydroCAD Software Solutions LLC

Type II 24-hr 25 Year Rainfall=4.19"

Printed 3/20/2023

Page 5

## Summary for Subcatchment 27S: **WS 2**

Runoff = 1.39 cfs @ 11.91 hrs, Volume= 0.063 af, Depth= 3.62"

Runoff by SCS TR-20 method, UH=SCS, Weighted-Q, Time Span= 0.00-72.00 hrs, dt= 0.01 hrs  
Type II 24-hr 25 Year Rainfall=4.19"

Area (ac)	CN	Description
* 0.208	95	Worksheet
0.208		100.00% Pervious Area

Tc (min)	Length (feet)	Slope (ft/ft)	Velocity (ft/sec)	Capacity (cfs)	Description
1.1					Direct Entry, Worksheet

### Subcatchment 27S: WS 2

Hydrograph



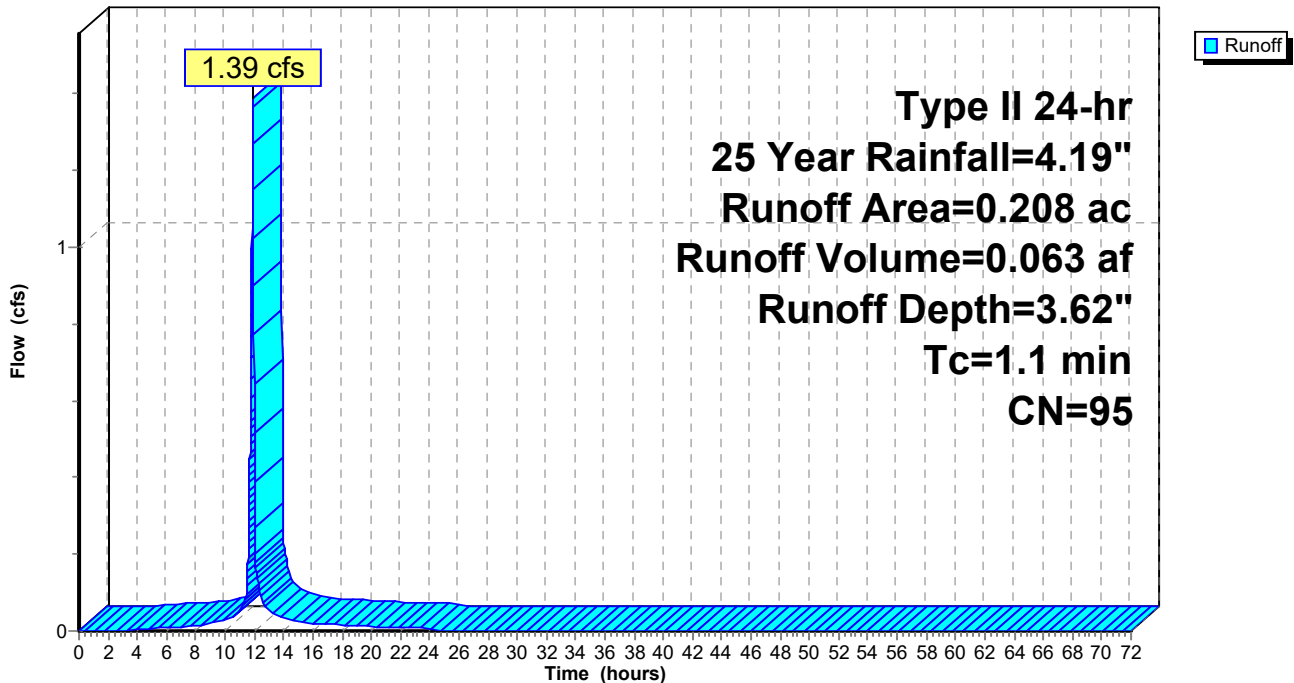

**22 Depot Storm**

Prepared by Krebs & Lansing Consulting Engineers, Inc.

HydroCAD® 10.00 s/n 06429 © 2013 HydroCAD Software Solutions LLC

Type II 24-hr 25 Year Rainfall=4.19"

Printed 3/20/2023

Page 6

**Summary for Subcatchment 31S: WS-Untreated**

Runoff = 0.39 cfs @ 11.92 hrs, Volume= 0.017 af, Depth= 3.10"

Runoff by SCS TR-20 method, UH=SCS, Weighted-Q, Time Span= 0.00-72.00 hrs, dt= 0.01 hrs  
Type II 24-hr 25 Year Rainfall=4.19"

Area (ac)	CN	Description
* 0.065	90	Worksheet
0.065		100.00% Pervious Area

Tc (min)	Length (feet)	Slope (ft/ft)	Velocity (ft/sec)	Capacity (cfs)	Description
1.5					Direct Entry, Worksheet

**Subcatchment 31S: WS-Untreated**

Hydrograph

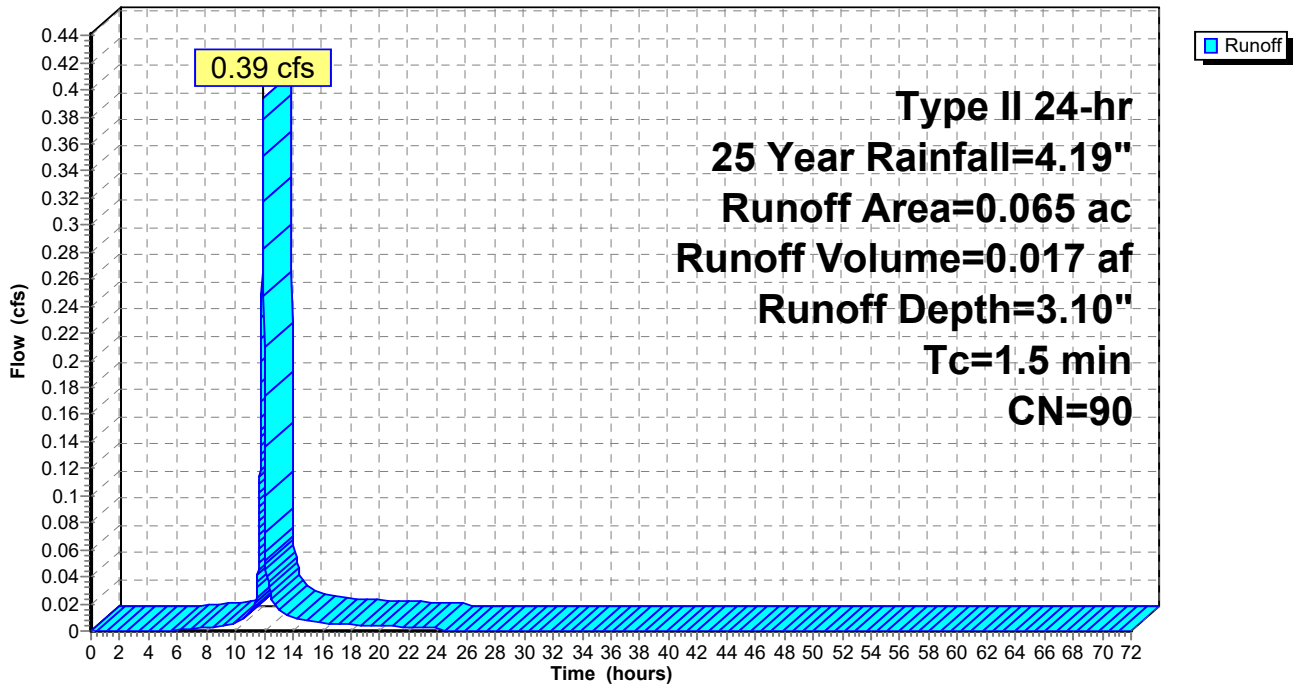

# 22 Depot Storm

Prepared by Krebs & Lansing Consulting Engineers, Inc.

HydroCAD® 10.00 s/n 06429 © 2013 HydroCAD Software Solutions LLC

Type II 24-hr 25 Year Rainfall=4.19"

Printed 3/20/2023

Page 7

## Summary for Subcatchment 32S: WS-Untreated

Runoff = 1.57 cfs @ 11.94 hrs, Volume= 0.071 af, Depth= 3.10"

Runoff by SCS TR-20 method, UH=SCS, Weighted-Q, Time Span= 0.00-72.00 hrs, dt= 0.01 hrs  
Type II 24-hr 25 Year Rainfall=4.19"

Area (ac)	CN	Description
* 0.273	90	Worksheet
0.273		100.00% Pervious Area

Tc (min)	Length (feet)	Slope (ft/ft)	Velocity (ft/sec)	Capacity (cfs)	Description
3.1					Direct Entry, Worksheet

## Subcatchment 32S: WS-Untreated

Hydrograph

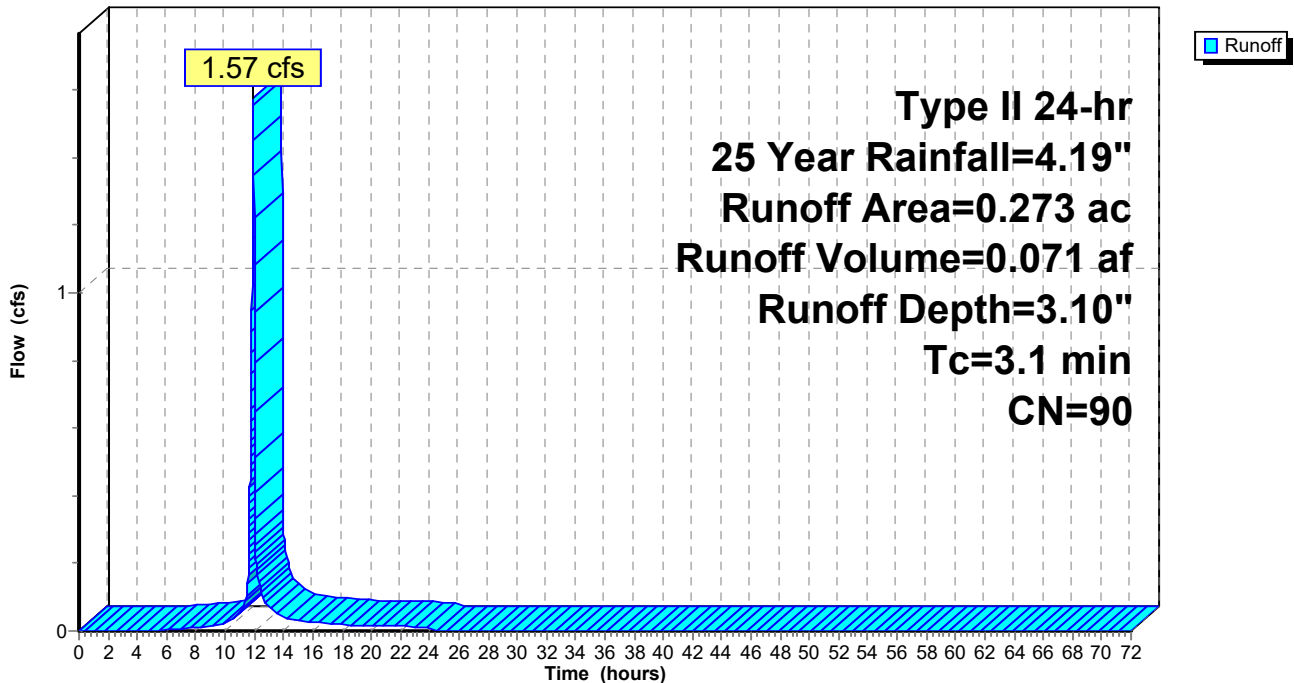

## 22 Depot Storm

Type II 24-hr 25 Year Rainfall=4.19"

Prepared by Krebs & Lansing Consulting Engineers, Inc.

Printed 3/20/2023

HydroCAD® 10.00 s/n 06429 © 2013 HydroCAD Software Solutions LLC

Page 8

### Summary for Pond 28P: Infiltration TrenchA

Inflow Area = 0.208 ac, 0.00% Impervious, Inflow Depth = 3.62" for 25 Year event  
 Inflow = 1.39 cfs @ 11.91 hrs, Volume= 0.063 af  
 Outflow = 1.02 cfs @ 11.96 hrs, Volume= 0.063 af, Atten= 27%, Lag= 3.1 min  
 Discarded = 0.07 cfs @ 11.25 hrs, Volume= 0.058 af  
 Primary = 0.95 cfs @ 11.96 hrs, Volume= 0.005 af

Routing by Stor-Ind method, Time Span= 0.00-72.00 hrs, dt= 0.01 hrs / 2  
 Peak Elev= 329.56' @ 11.96 hrs Surf.Area= 377 sf Storage= 926 cf

Plug-Flow detention time= (not calculated: outflow precedes inflow)  
 Center-of-Mass det. time= 86.3 min ( 851.3 - 765.0 )

5 chambers  
 Provided

Volume	Invert	Avail.Storage	Storage Description
#1	329.45'	8 cf	<b>Custom Stage Data (Prismatic)</b> Listed below (Recalc)
#2A	323.95'	340 cf	<b>7.42'W x 40.62'L x 4.75'H Field A</b> 1,431 cf Overall - 581 cf Embedded = 850 cf x 40.0% Voids
#3A	324.45'	581 cf	<b>ADS_StormTech MC-3500 c +Cap x 5</b> Inside #2 Effective Size= 70.4"W x 45.0"H => 15.33 sf x 7.17'L = 110.0 cf Overall Size= 77.0"W x 45.0"H x 7.50'L with 0.33' Overlap Cap Storage= +15.6 cf x 2 x 1 rows = 31.2 cf
		929 cf	Total Available Storage

Storage Group A created with Chamber Wizard

Elevation (feet)	Surf.Area (sq-ft)	Inc.Store (cubic-feet)	Cum.Store (cubic-feet)
329.45	10	0	0
329.60	100	8	8

Device	Routing	Invert	Outlet Devices
#1	Discarded	323.95'	<b>10.000 in/hr Exfiltration over Surface area below 323.96'</b>
#2	Primary	329.45'	<b>10.0' long x 4.0' breadth Broad-Crested Rectangular Weir</b> Head (feet) 0.20 0.40 0.60 0.80 1.00 1.20 1.40 1.60 1.80 2.00 2.50 3.00 3.50 4.00 4.50 5.00 5.50 Coef. (English) 2.38 2.54 2.69 2.68 2.67 2.67 2.65 2.66 2.66 2.68 2.72 2.73 2.76 2.79 2.88 3.07 3.32

**Discarded OutFlow** Max=0.07 cfs @ 11.25 hrs HW=324.01' (Free Discharge)  
 ↑1=Exfiltration (Exfiltration Controls 0.07 cfs)

**Primary OutFlow** Max=0.82 cfs @ 11.96 hrs HW=329.56' (Free Discharge)  
 ↑2=Broad-Crested Rectangular Weir (Weir Controls 0.82 cfs @ 0.77 fps)

## 22 Depot Storm

Prepared by Krebs & Lansing Consulting Engineers, Inc.

HydroCAD® 10.00 s/n 06429 © 2013 HydroCAD Software Solutions LLC

Type II 24-hr 25 Year Rainfall=4.19"

Printed 3/20/2023

Page 9

### Pond 28P: Infiltration TrenchA - Chamber Wizard Field A

**Chamber Model = ADS\_StormTech MC-3500 c +Cap (ADS StormTech® MC-3500 c rev 05/12 with Cap storage)**

Effective Size= 70.4"W x 45.0"H => 15.33 sf x 7.17'L = 110.0 cf

Overall Size= 77.0"W x 45.0"H x 7.50'L with 0.33' Overlap

Cap Storage= +15.6 cf x 2 x 1 rows = 31.2 cf

5 Chambers/Row x 7.17' Long +1.88' Cap Length x 2 = 39.62' Row Length +6.0" End Stone x 2 = 40.62' Base Length

1 Rows x 77.0" Wide + 6.0" Side Stone x 2 = 7.42' Base Width

6.0" Base + 45.0" Chamber Height + 6.0" Cover = 4.75' Field Height

5 Chambers x 110.0 cf + 15.6 cf Cap Volume x 2 x 1 Rows = 581.0 cf Chamber Storage

1,430.9 cf Field - 581.0 cf Chambers = 849.9 cf Stone x 40.0% Voids = 340.0 cf Stone Storage

Chamber Storage + Stone Storage = 920.9 cf = 0.021 af

Overall Storage Efficiency = 64.4%

5 Chambers

53.0 cy Field

31.5 cy Stone

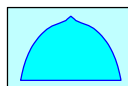
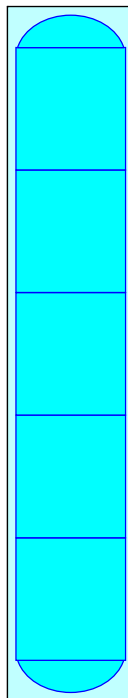

**22 Depot Storm**

Prepared by Krebs & Lansing Consulting Engineers, Inc.

HydroCAD® 10.00 s/n 06429 © 2013 HydroCAD Software Solutions LLC

Type II 24-hr 25 Year Rainfall=4.19"

Printed 3/20/2023

Page 10

**Pond 28P: Infiltration TrenchA**

Hydrograph

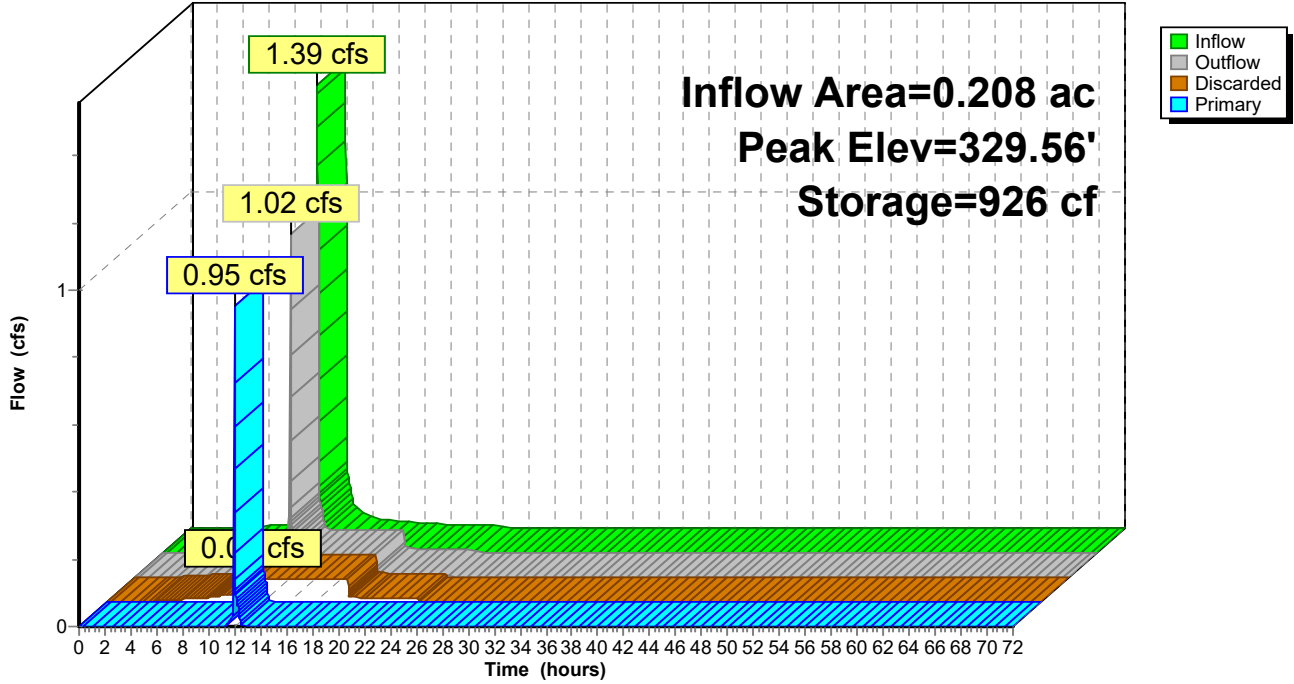

Post development peak discharge rate for 25 year storm = 1.22 cfs. Less than pre development peak

## 22 Depot Storm

Prepared by Krebs & Lansing Consulting Engineers, Inc.  
HydroCAD® 10.00 s/n 06429 © 2013 HydroCAD Software Solutions LLC

Type II 24-hr 25 Year Rainfall=4.19"

Printed 3/20/2023

Page 11

### Summary for Link 29L: Off Site

Inflow Area = 0.273 ac, 0.00% Impervious, Inflow Depth = 0.96" for 25 Year event  
Inflow = 1.22 cfs @ 11.96 hrs, Volume= 0.022 af  
Primary = 1.22 cfs @ 11.96 hrs, Volume= 0.022 af, Atten= 0%, Lag= 0.0 min

Primary outflow = Inflow, Time Span= 0.00-72.00 hrs, dt= 0.01 hrs

### Link 29L: Off Site

Hydrograph

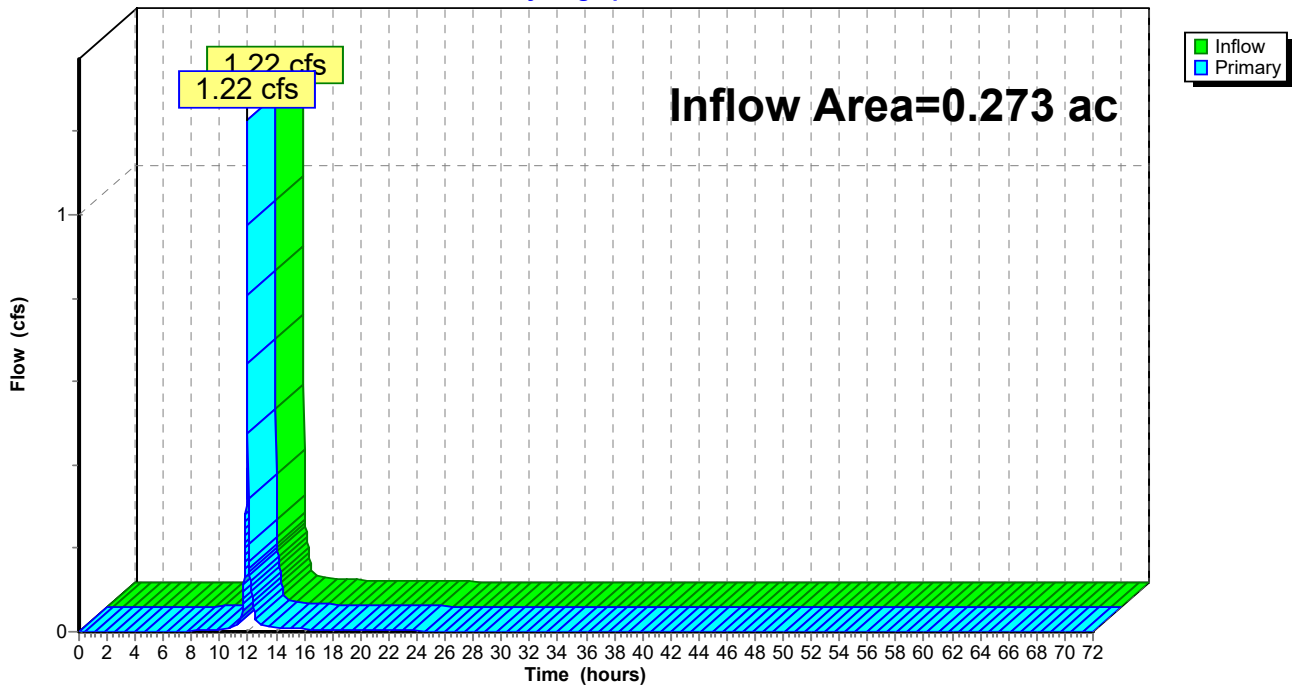

Pre development peak discharge rate for 25 year storm = 1.57 cfs.

## 22 Depot Storm

Prepared by Krebs & Lansing Consulting Engineers, Inc.  
HydroCAD® 10.00 s/n 06429 © 2013 HydroCAD Software Solutions LLC

Type II 24-hr 25 Year Rainfall=4.19"

Printed 3/20/2023

Page 12

### Summary for Link 33L: Off Site

Inflow Area = 0.273 ac, 0.00% Impervious, Inflow Depth = 3.10" for 25 Year event  
Inflow = 1.57 cfs @ 11.94 hrs, Volume= 0.071 af  
Primary = 1.57 cfs @ 11.94 hrs, Volume= 0.071 af, Atten= 0%, Lag= 0.0 min

Primary outflow = Inflow, Time Span= 0.00-72.00 hrs, dt= 0.01 hrs

### Link 33L: Off Site

Hydrograph

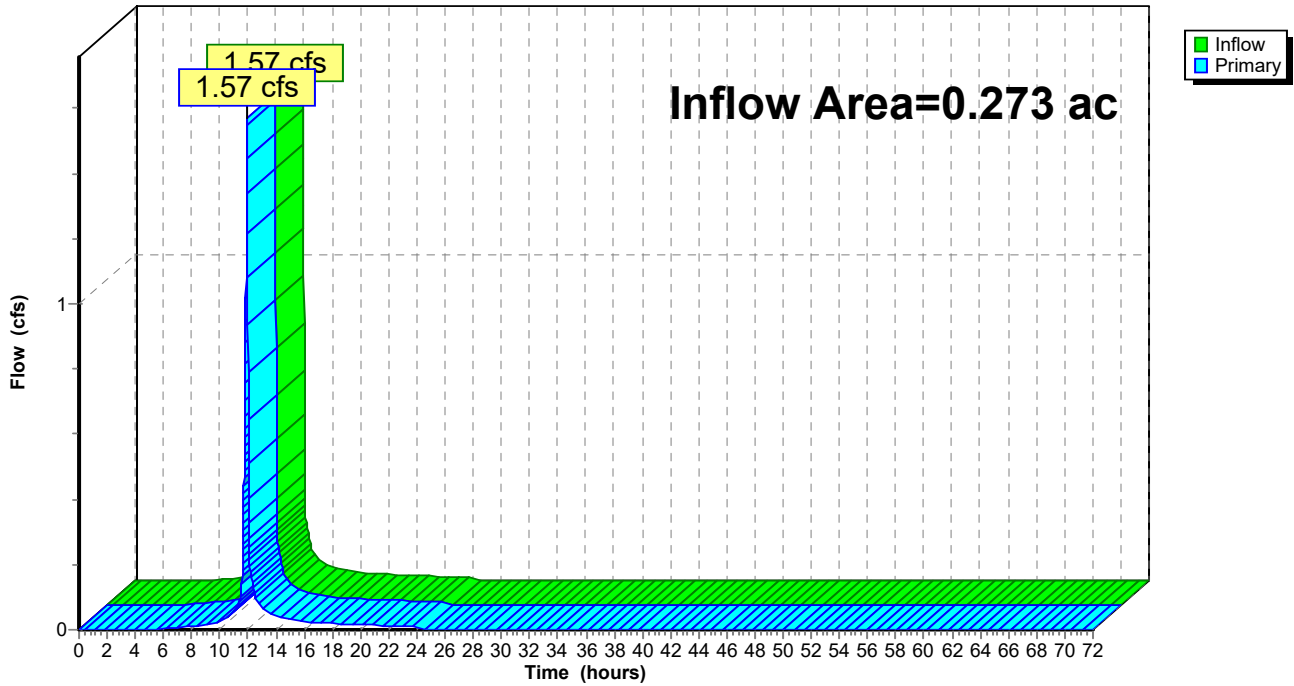







---

**Re: 22 Depot Street - Waterline Plans for Review**

---

**Tyler Billingsley** <tyler@eastengineeringplc.com>  
To: Derick Read <Derick.Read@krebsandlansing.com>  
Cc: Allen Carpenter <acarpenter@richmondvt.gov>

Fri, Apr 21, 2023 at 3:29 PM

Looks good to me - thanks.

Tyler

On Fri, Apr 21, 2023 at 3:25 PM Derick Read <Derick.Read@krebsandlansing.com> wrote:  
Thanks Allen.

Tyler please feel free to call my cell if you have any questions.

Thanks  
Derick  
Derick Read, P.E.  
Krebs & Lansing Consulting Engineers, Inc.  
164 Main Street  
Colchester, Vermont 05446  
O: (802) 878-0375  
C: (802) 598-9911  
[Derick.Read@krebsandlansing.com](mailto:Derick.Read@krebsandlansing.com)

On Fri, Apr 21, 2023 at 3:20 PM Allen Carpenter <acarpenter@richmondvt.gov> wrote:  
I did not see anything I noticed. I sent it to tyler to see if he has any questions?  
Allen Carpenter

On Fri, Apr 21, 2023 at 11:24 AM Allen Carpenter <acarpenter@richmondvt.gov> wrote:  
Here are there drawings plans 22 depot st

On Fri, Apr 21, 2023 at 11:15 AM Tyler Billingsley <tyler@eastengineeringplc.com> wrote:  
Can you attach the plans? They aren't showing up as an attachment.

Tyler

On Fri, Apr 21, 2023 at 11:10 AM Allen Carpenter <acarpenter@richmondvt.gov> wrote:  
It looks good to me. Do you see anything tyler?  
Allen Carpenter

----- Forwarded message -----

From: **Josh Arneson** <jarneson@richmondvt.gov>  
Date: Thu, Apr 20, 2023 at 4:04 PM  
Subject: Re: 22 Depot Street - Waterline Plans for Review  
To: Allen Carpenter <acarpenter@richmondvt.gov>

Allen,

Please respond to Derick on these plans. Have Tyler Billingsley review them if you need to. Please copy me on your reply.

Thanks,

Josh Arneson (he/him)

Town Manager  
Town of Richmond  
P.O. Box 285  
Richmond, VT 05477  
(802) 434-5170

On Thu, Apr 20, 2023 at 2:57 PM Derick Read <Derick.Read@krebsandlansing.com> wrote:  
Hi Allen,

I wanted to touch base to see if you've had a chance to look at our design plans for the proposed project at 22 Depot Street? I don't know if you care but I added the stormwater related plans and hydroCAD modeling calculations for the proposed underground stormwater chamber infiltration system that will be installed under the parking lot behind the building. You will see that we are disconnecting the existing building roof gutter from the sewer and connecting it to the infiltration system.

Please feel free to call if you have any questions.

Thanks

Derick

Derick Read, P.E.

Krebs & Lansing Consulting Engineers, Inc.

164 Main Street

Colchester, Vermont 05446

O: (802) 878-0375

C: (802) 598-9911

[Derick.Read@krebssandlansing.com](mailto:Derick.Read@krebssandlansing.com)

On Thu, Apr 6, 2023 at 11:17 AM Derick Read <[Derick.Read@krebssandlansing.com](mailto:Derick.Read@krebssandlansing.com)> wrote:

Hi Josh and Allen,

We're continuing to move forward and permitting and construction documents for the 22 Depot Street project. I've attached our current site plans and related details for your review. Please feel free to call if you have any questions.

Thanks

Derick

Derick Read, P.E.

Krebs & Lansing Consulting Engineers, Inc.

164 Main Street

Colchester, Vermont 05446

O: (802) 878-0375

C: (802) 598-9911

[Derick.Read@krebssandlansing.com](mailto:Derick.Read@krebssandlansing.com)

--

Tyler Billingsley, P.E.

Engineer / Owner

[tyler@eastengineeringplc.com](mailto:tyler@eastengineeringplc.com)

802-989-6686

--

Tyler Billingsley, P.E.

Engineer / Owner

[tyler@eastengineeringplc.com](mailto:tyler@eastengineeringplc.com)

802-989-6686