

ZONING INFORMATION	
ZONING DISTRICT	
AGRICULTURAL RESIDENTIAL DISTRICT (AR)	
DIMENSIONAL REQUIREMENTS	
LOT AREA:	1 ACRE MIN.
LOT FRONTAGE:	100 FT. MIN.
SETBACK - FRONT YARD:	
FRONT LOT LINE:	30 FT. MIN.
ROAD CENTERLINE:	55 FT. MIN.
SETBACK - SIDE YARD:	
PRINCIPAL STRUCTURE:	20 FT. MIN.
ACCESSORY STRUCTURE:	10 FT. MIN.
SETBACK - REAR YARD:	
PRINCIPAL STRUCTURE:	20 FT. MIN.
ACCESSORY STRUCTURE:	10 FT. MIN.
LOT COVERAGE:	30% MAX.
BUILDING HEIGHT:	35 FT. MAX.

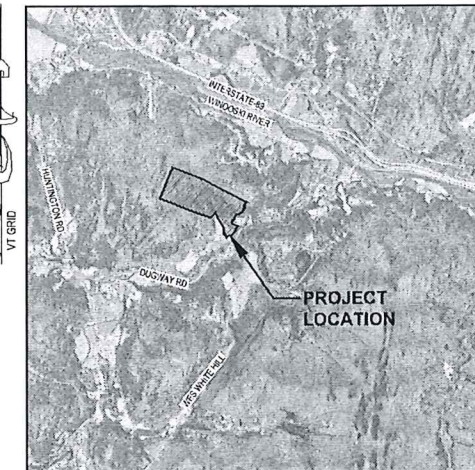
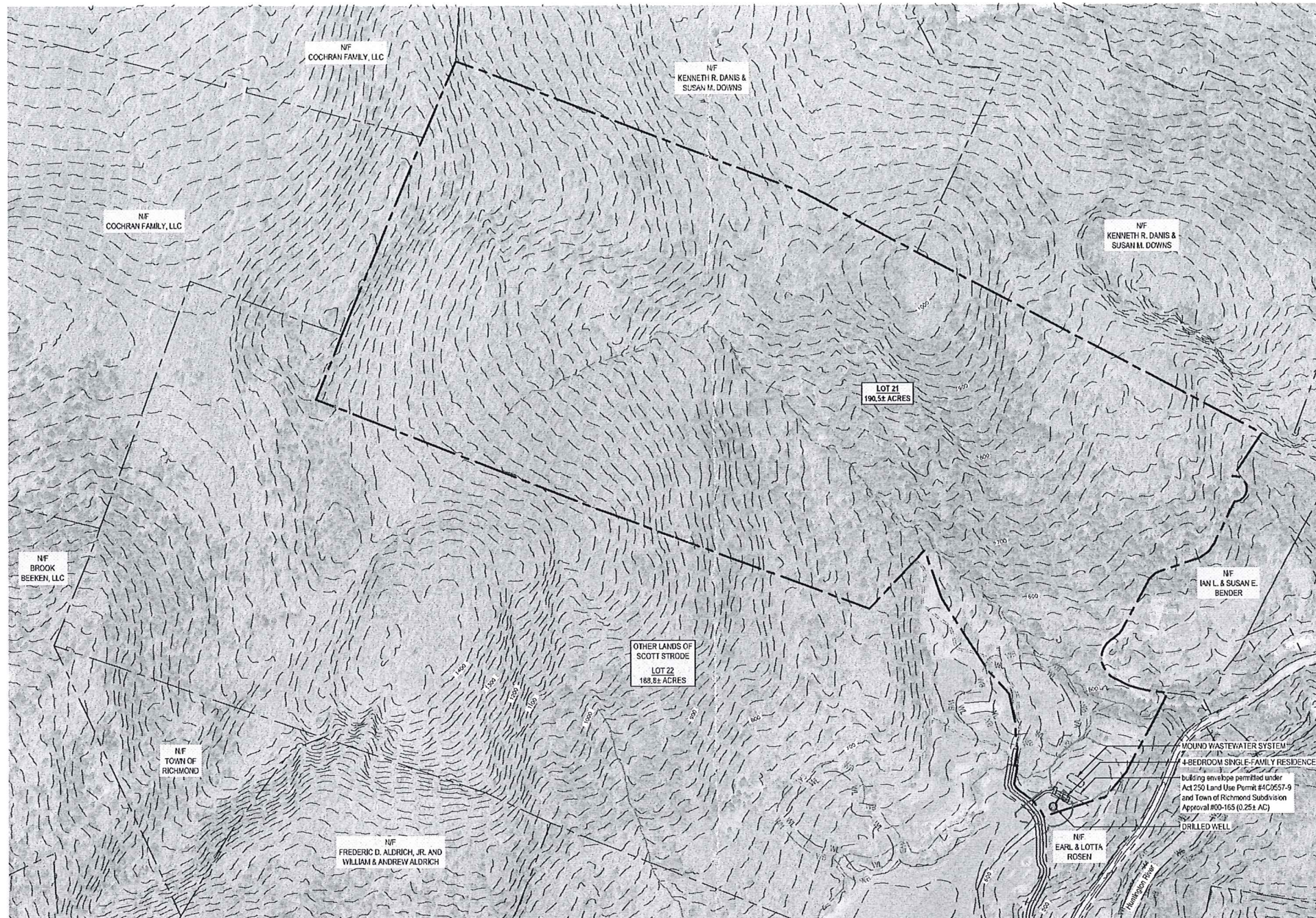

Project Location Map
Not to Scale

LEGEND	
---	BOUNDARY LINE/ R.O.W. (SUBJECT PARCEL)
---	BOUNDARY LINE/ R.O.W. (ABUTTING PARCEL)
---	SIDELINE OF EASEMENT
---	EDGE OF ROAD/DRIVE (SURFACE NOTED)
100	20-FOOT LIDAR CONTOUR (OBTAINED FROM VCGI DATABASE)
100	20-FOOT GROUND SURVEY CONTOUR
100	FINISH GRADE
---	ZONING DISTRICT BOUNDARY
---	BUILDING ENVELOPE
---	STONE WALL (EXISTING)
---	STREAM CENTERLINE
S	GRAVITY SEWER
FM	FORCE MAIN
W	1-INCH DIAMETER CL200 POLYETHYLENE PLASTIC WATER LINE (UNLESS OTHERWISE NOTED)
---	WELL ISOLATION
---	WASTEWATER ISOLATION
W	WETLAND BOUNDARY
WB	WETLAND BUFFER
ue	UNDERGROUND ELECTRICAL (EXISTING)
UE	UNDERGROUND ELECTRICAL (PROPOSED)
chw	UTILITY POLE/ OVERHEAD WIRES (EXISTING)
CHW	UTILITY POLE/ OVERHEAD WIRES (PROPOSED)
▲	SURVEY TRAVERSE STATION
●	TEST PIT (TP-01)
●	SOIL BORING (SB-01)
⊕	DRILLED WELL (UNLESS OTHERWISE NOTED)

PROJECT NOTES:

- THIS IS NOT A BOUNDARY SURVEY. PROJECT PERIMETER LINES ARE BASED ON A PLAN ENTITLED "PLAN OF LAND FOR EARL & LOTTI ROSEN, PORTION OF "PARAMOUNT FARMS" ON THE NORTHERLY SIDE OF "DUGWAY ROAD", RICHMOND, VERMONT, BY DAVID J. PEATMAN, DATED AUGUST 9, 2000 AND LAST REVISED DECEMBER 21, 2000.
- THE LOCATIONS OF EXISTING PHYSICAL FEATURES ON THIS PLAN ARE BASED ON A TOPOGRAPHIC SURVEY COMPLETED BY BARNARD AND GERVAIS, LLC IN DECEMBER 2021.
- THE ELEVATIONS ON THIS PLAN WITHIN THE DASHED BOUNDARIES SHOWN ARE BASED ON NAVD83 (GEOID 128) ESTABLISHED FROM SURVEY GRADE GNSS READINGS COLLECTED WITH A TOPCON HIFER SR GNSS RECEIVER ADJUSTED TO VERMONT GRID ON RANDOM CONTROL POINTS USING REAL TIME KINEMATIC CORRECTIONS FROM A VIRTUAL REFERENCE STATION OF THE VT CORS NETWORK. THE ELEVATIONS ON THIS PLAN OUTSIDE THE DASHED BOUNDARIES SHOWN ARE LIDAR CONTOURS OBTAINED FROM THE STATE OF VERMONT VCGI OPEN DATA PORTAL DATABASE.
- FOR CLARITY, TEXT IDENTIFYING EXISTING ITEMS IS LOWER CASE; TEXT IDENTIFYING PROPOSED ITEMS IS UPPER CASE.
- NO ATTEMPT HAS BEEN MADE TO LOCATE ANY UNDERGROUND UTILITIES BY BARNARD AND GERVAIS, LLC. THE CONTRACTOR WILL BE RESPONSIBLE FOR CONTACTING DIG SAFE TO HAVE ANY UNDERGROUND UTILITIES MARKED PRIOR TO ANY EXCAVATION OR SITE WORK. THE CONTRACTOR SHALL NOTIFY THE DIG SAFE NETWORK AT LEAST 72 HOURS PRIOR TO THE START OF CONSTRUCTION.
- THE WASTEWATER DISPOSAL SYSTEM HAS BEEN DESIGNED IN ACCORDANCE WITH THE STATE OF VERMONT, AGENCY OF NATURAL RESOURCES, ENVIRONMENTAL PROTECTION RULES, CHAPTER 1, "WASTEWATER SYSTEM AND POTABLE WATER SUPPLY RULES" EFFECTIVE APRIL 12, 2019.
- THE PROPOSED DRILLED WELL SITE IS SHOWN BASED ON THE REQUIRED ISOLATION DISTANCES TO THE PROPOSED WASTEWATER DISPOSAL SYSTEM AND THE ASSOCIATED SYSTEM COMPONENTS. NO WARRANTY IS MADE REGARDING THE WELL YIELD OR WATER QUALITY RELATIVE TO THE DRILLED WELL LOCATION SHOWN HEREON.

- NO WETLANDS WERE SHOWN IN THE VICINITY OF THE PROJECT AREA ON THE "VERMONT NATURAL RESOURCES ATLAS" AND NO OTHER WETLAND DELINEATION OF SAID PARCEL HAS BEEN CONDUCTED OF WHICH BARNARD & GERVAIS, LLC IS AWARE. WETLANDS SHOWN HEREON ARE BASED ON THE STATE OF VERMONT AGENCY OF NATURAL RESOURCES (AVR) ENVIRONMENTAL INTEREST LOCATOR AND THE VERMONT STATE WETLANDS INVENTORY (VSWI) LAYER. BARNARD & GERVAIS, LLC DOES NOT CLAIM TO BE WETLAND ECOLOGISTS AND DOES NOT HAVE A WETLAND ECOLOGIST OR SPECIALIST ON STAFF. IT IS RECOMMENDED THAT THE LANDOWNER OR CONTRACTOR CONTACT A WETLAND SPECIALIST TO CONFIRM NO WETLANDS EXIST PRIOR TO ANY EARTH WORK OR CONSTRUCTION.
- BARNARD & GERVAIS, LLC IS NOT RESPONSIBLE FOR ANY ASPECTS OF HEALTH AND SAFETY ASSOCIATED WITH THIS PROJECT.
- ALL EXCAVATION WORK SHALL BE PERFORMED IN ACCORDANCE WITH APPLICABLE STATE OF VERMONT, OCCUPATIONAL SAFETY AND HEALTH ADMINISTRATION (OSHA) GUIDELINES FOR TRENCH EXCAVATIONS.
- THE CONTRACTOR AND/OR LANDOWNER SHALL ADHERE TO THE GUIDELINES SET FORTH IN THE STATE OF VERMONT EROSION AND SEDIMENT CONTROL HANDBOOK FOR CONSTRUCTION SITES. IT IS THE RESPONSIBILITY OF THE LANDOWNER OR SITE CONTRACTOR TO ENSURE THESE GUIDELINES ARE FOLLOWED AND EROSION/SEDIMENT CONTROL MEASURES ARE MAINTAINED THROUGHOUT THE COURSE OF THE PROJECT.
- AS SHOWN, THE PROJECT CONTAINS 4810± SF OF IMPERVIOUS SURFACE AREA.
- THE PROPERTY IS SUBJECT TO STATE OF VERMONT ACT 250 LAND USE PERMIT #4C0557-9 AND TOWN OF RICHMOND SUBDIVISION APPROVAL #00-165
- THE PROPOSED SHARED ACCESS WAS DESIGNED BY CHAMPLAIN CONSULTING ENGINEERS AND IS PERMITTED UNDER ACT 250 LAND USE PERMIT #4C0557-9 AND TOWN OF RICHMOND SUBDIVISION APPROVAL #00-165.

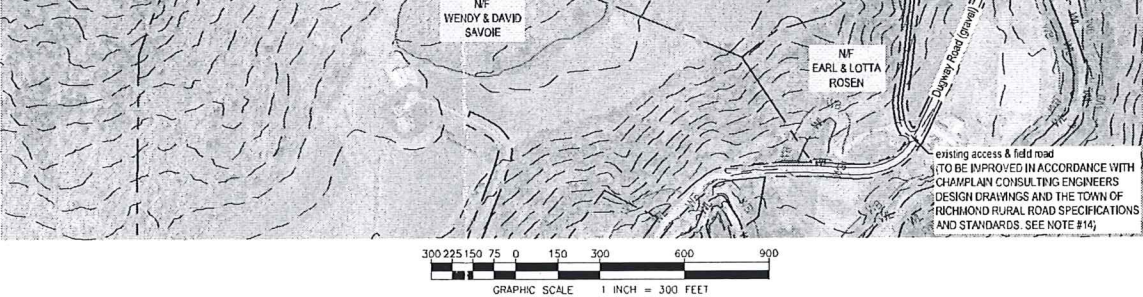

OWNER:
SCOTT STRODE
DEED - Vol. 263, PG. 221
SPAN # 519-163-11336
PARCEL ID # DG1500 c

SIGNATURE:

JASON S. BARNARD
LICENSED DESIGNER #126179

DATE	DESCRIPTION	BY
REVISIONS		
LOT 21 SINGLE-FAMILY RESIDENCE: WATER SUPPLY AND WASTEWATER DISPOSAL SYSTEM DESIGN		PROJECT NO. 21315
SCOTT STRODE		DATE: 03-23-2022
DUGWAY ROAD, RICHMOND, VERMONT		SCALE: 1" = 300'
OVERALL SITE PLAN		SURVEY: AW, OL
THESE PLANS WITH LATEST REVISIONS SHOULD ONLY BE USED FOR THE PURPOSE SHOWN BELOW.		DRAWN: SB
<input type="checkbox"/> PRELIMINARY DRAFT <input checked="" type="checkbox"/> FINAL STATE REVIEW		CHECKED: JB
		DRAWING NO. S-1
		SHEET 1 OF 3

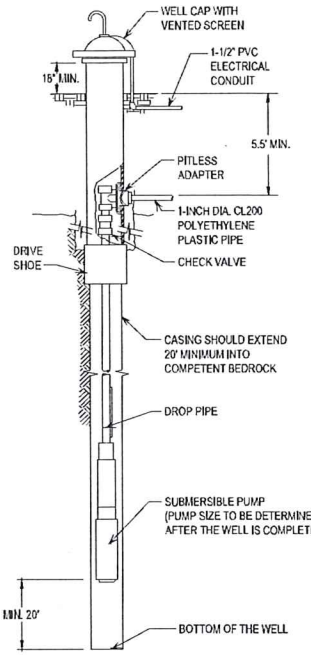

DRILLED WELL REQUIRED MINIMUM ISOLATION DISTANCES

1. THESE DISTANCES APPLY TO DRILLED WELLS SERVING A SINGLE-FAMILY RESIDENCE, WITH A MAXIMUM DAILY DEMAND OF LESS THAN 1.9 GPM.

2. THE DRILLED WELL SHALL BE CONSTRUCTED IN ACCORDANCE WITH §1-1205 OF THE STATE OF VERMONT ENVIRONMENTAL PROTECTION RULES, CHAPTER 1, EFFECTIVE APRIL 12, 2019.

POTENTIAL SOURCE OF CONTAMINATION	SEPARATION DISTANCE
SEWAGE DISPOSAL FIELD WITH FLOWS $\leq 2000\text{ GPD}$	24 FEET IF WELL IS DOWNSLOPE
SUBSURFACE WASTEWATER PIPING	10 FEET IF WELL IS UPSLOPE
EDGE OF RESIDENTIAL DRIVE SERVING 3 OR MORE RESIDENCES	5 FEET
PROPERTY LINE	5 FEET
BUILDINGS	16 FEET
LIMIT OF HERBICIDE APPLICATION ON UTILITY RIGHT-OF-WAY	5 FEET
SURFACE WATER	16 FEET
CONCENTRATED LIVESTOCK HOLDING AREAS AND MANURE STORAGE	26 FEET
HAZARDOUS OR SOLID WASTE DISPOSAL SITE	5 FEET
NON-SEWAGE WASTEWATER DISPOSAL FIELDS	10 FEET
	24 FEET
	CONTACT DESIGNER
	CONTACT DESIGNER

NOTES:

- THE DRILLED WELL SHALL BE CONSTRUCTED IN ACCORDANCE WITH §1-1205 OF THE STATE OF VERMONT ENVIRONMENTAL PROTECTION RULES, CHAPTER 1, EFFECTIVE APRIL 12, 2019.
- THE DRILLED WELL LOCATION SHALL ADHERE TO THE ISOLATION DISTANCES SHOWN ON THE DRILLED WELL ISOLATION TABLE ABOVE.

DRILLED WELL CONSTRUCTION DETAIL
NOT TO SCALE

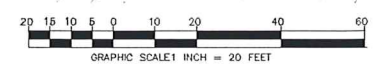
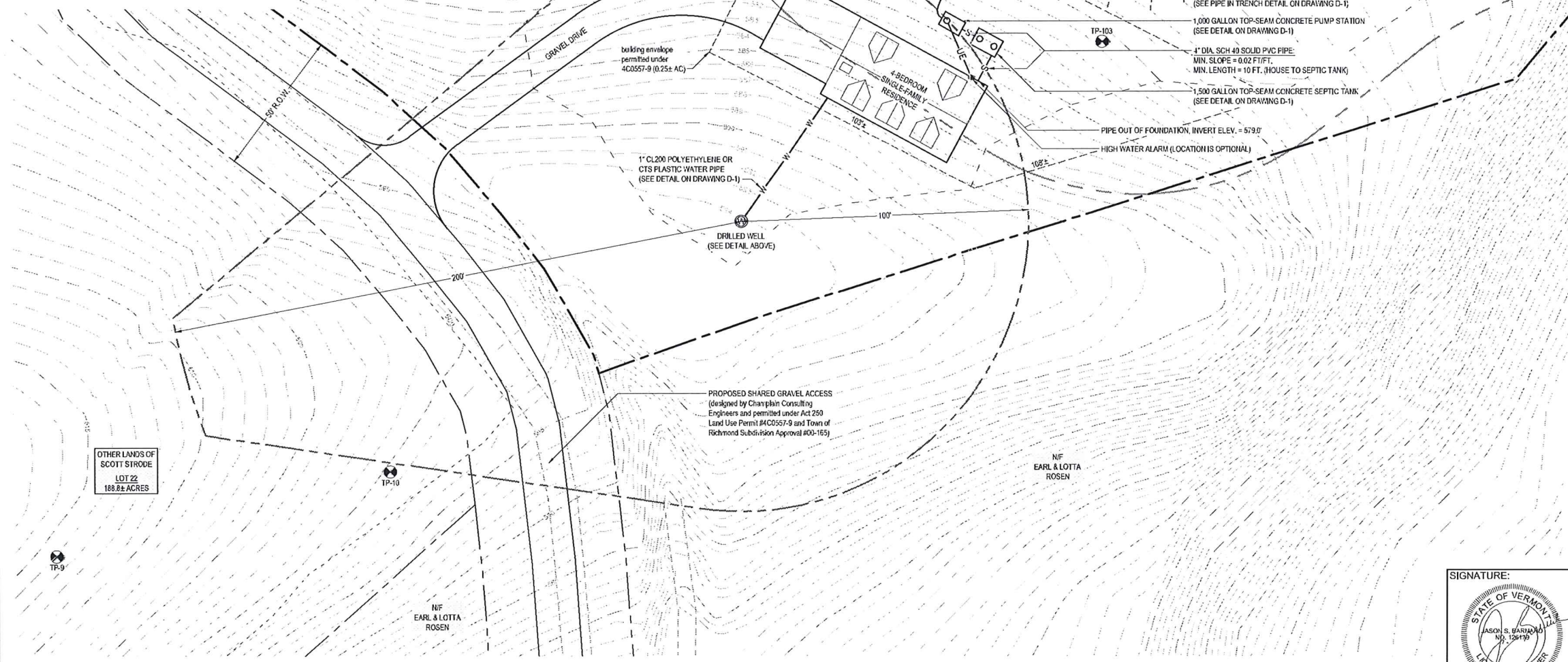

LEGEND

---	BOUNDARY LINE/ R.O.W. (SUBJECT PARCEL)
---	BOUNDARY LINE/ R.O.W. (ABUTTING PARCEL)
---	SIDELINE OF EASEMENT
---	EDGE OF ROAD/DRIVE (SURFACE NOTED)
---	1-FOOT LIDAR CONTOUR (OBTAINED FROM VCGI DATABASE)
---	1-FOOT GROUND SURVEY CONTOUR
---	FINISH GRADE
---	ZONING DISTRICT BOUNDARY
---	BUILDING ENVELOPE
---	TREE LINE
---	PROPOSED LIMITS OF CLEARING
---	STONE WALL (EXISTING)
---	STREAM CENTERLINE
---	DITCHLINE
---	GRAVITY SEWER (EXISTING)
---	GRAVITY SEWER (PROPOSED)
---	FORCE MAIN
---	1-INCH DIAMETER CL200 POLYETHYLENE PLASTIC WATER LINE (UNLESS OTHERWISE NOTED)
---	WELL ISOLATION
---	WASTEWATER ISOLATION
---	SILT FENCE
---	WETLAND BOUNDARY
---	WETLAND BUFFER
---	UNDERGROUND ELECTRICAL (EXISTING)
---	UNDERGROUND ELECTRICAL (PROPOSED)
---	UTILITY POLE/ OVERHEAD WIRES (EXISTING)
---	UTILITY POLE/ OVERHEAD WIRES (PROPOSED)
---	SURVEY TRAVERSE STATION
---	TEMPORARY BENCHMARK (TYPE AND ELEVATION NOTED)
---	TEST PIT (TP-01)
---	SOIL BORING (SB-01)
---	DRILLED WELL (UNLESS OTHERWISE NOTED)

DATE	DESCRIPTION	BY
REVISIONS		
BARNARD & GERVAIS, LLC Land Surveying Water & Wastewater Environmental Consulting 167 Main Street, P.O. Box 820 Enosburg Falls, VT 05450 Telephone: (802) 933-5163		10523 VT Route 116, P.O. Box 133 Hinesburg, VT 05451 Telephone: (802) 483-2597
LOT 21 SINGLE-FAMILY RESIDENCE; WATER SUPPLY AND WASTEWATER DISPOSAL SYSTEM DESIGN		PROJECT NO. 21315
SCOTT STRODE		DATE: 03-23-2022
DUGWAY ROAD, RICHMOND, VERMONT		SCALE: 1" = 20'
SITE PLAN		SURVEY: AW, OL
THESE PLANS WITH LATEST REVISIONS SHOULD ONLY BE USED FOR THE PURPOSE SHOWN BELOW.		DRAWN: SB
<input type="checkbox"/> PRELIMINARY DRAFT <input checked="" type="checkbox"/> FINAL STATE REVIEW		CHECKED: JB
JASON S. BARNARD LICENSED DESIGNER #126179		DRAWING NO. S-2
		SHEET 2 OF 3

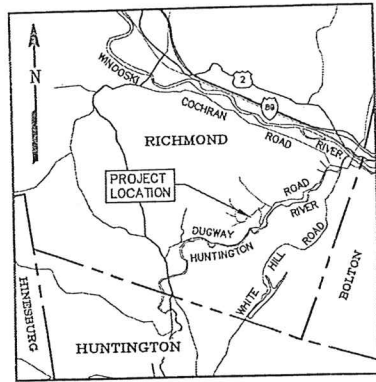

LOCATION MAP
N.T.S.

LEGEND

	TEST PIT
	CONTROL POINT
	UTILITY POLE
	IRON PIPE/ROD FOUND
	WELL
	FLAG
	ROCK OUTCROP
	EXISTING CONTOURS
	PROPOSED CONTOURS
	APPROX. BOUNDARY
	TREELINE
	BARBED WIRE FENCE
	STONE WALL

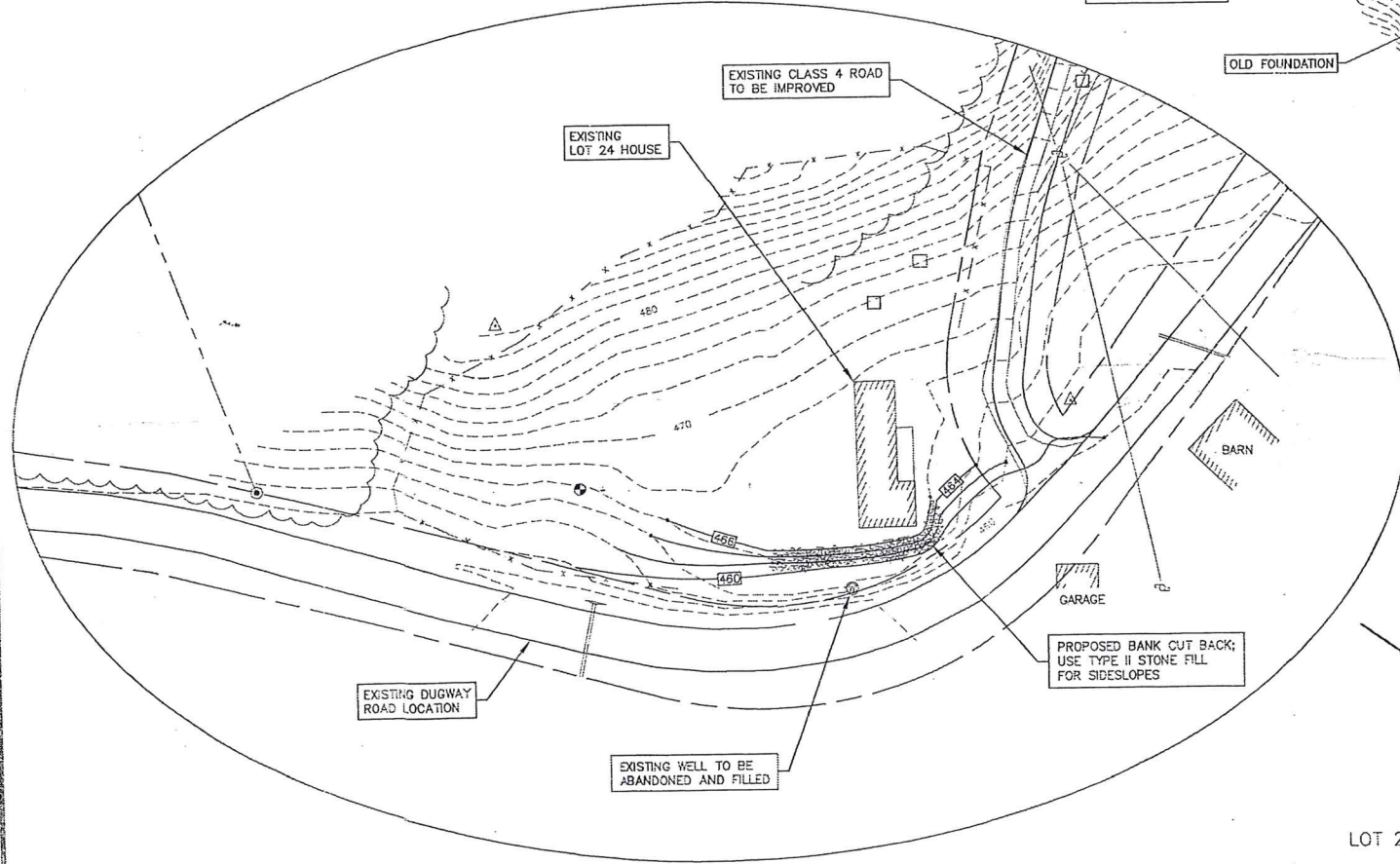

PARTIAL SITE PLAN
SCALE 1" = 40'

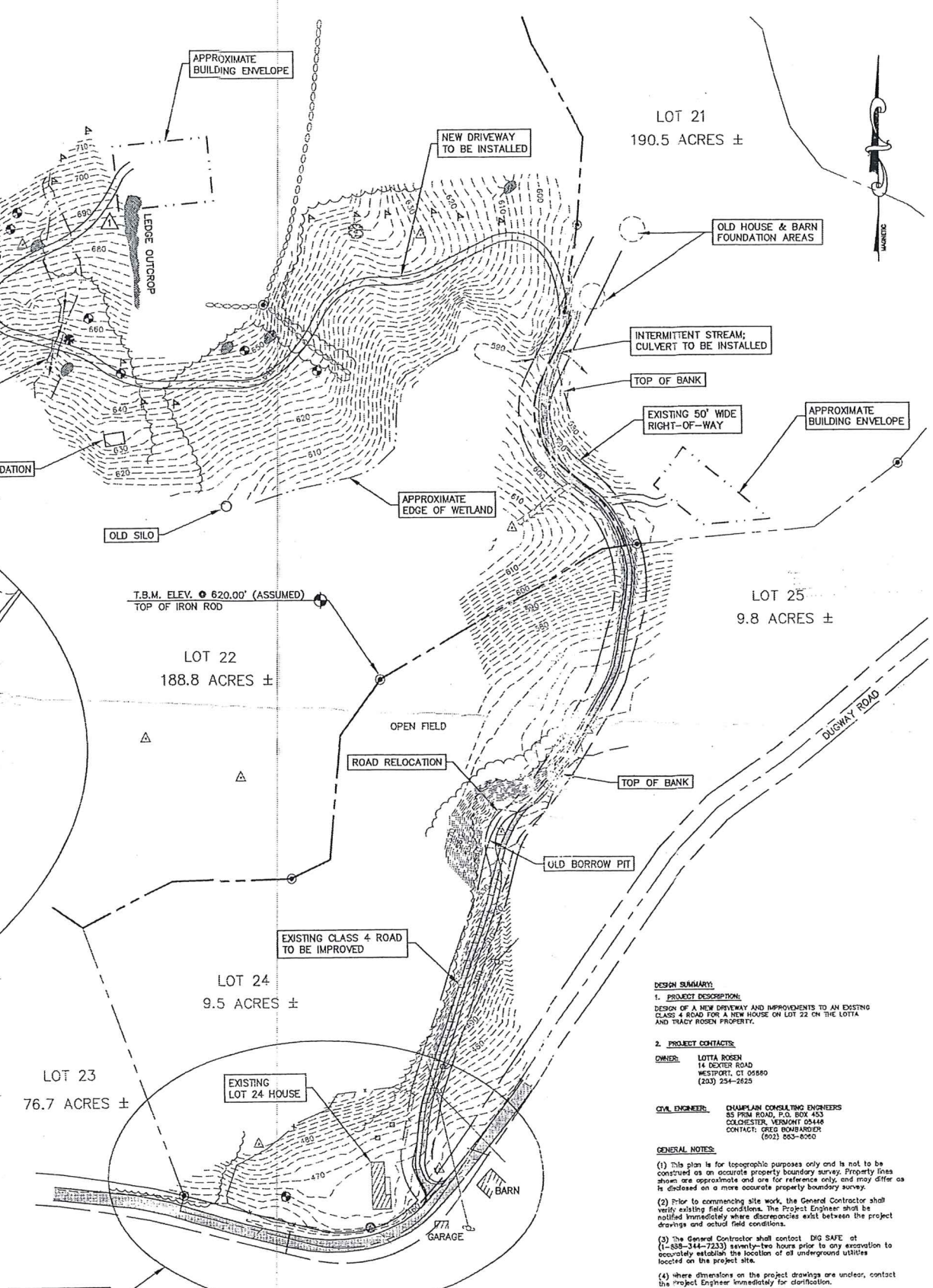
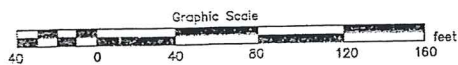

SITE PLAN
SCALE 1" = 100'

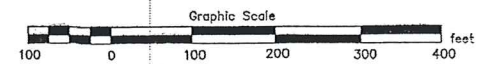

DESIGN SUMMARY:

1. **PROJECT DESCRIPTION:**
DESIGN OF A NEW DRIVEWAY AND IMPROVEMENTS TO AN EXISTING CLASS 4 ROAD FOR A NEW HOUSE ON LOT 22 ON THE LOTTA AND TRACY ROSEN PROPERTY.

2. **PROJECT CONTACTS:**

OWNER: LOTTA ROSEN
14 DEXTER ROAD
WESTPORT, CT 06880
(203) 234-2625

CIVIL ENGINEER: CHAMPLAIN CONSULTING ENGINEERS
85 PRIM ROAD, P.O. BOX 453
COLCHESTER, VERMONT 05448
CONTACT: GREG BOMBARDIER (802) 863-8000

GENERAL NOTES:

(1) This plan is for topographic purposes only and is not to be construed as an accurate property boundary survey. Property lines shown are approximate and are for reference only, and may differ as disclosed on a more accurate property boundary survey.

(2) Prior to commencing site work, the General Contractor shall verify existing field conditions. The Project Engineer shall be notified immediately where discrepancies exist between the project drawings and actual field conditions.

(3) The General Contractor shall contact DIG SAFE at (1-888-344-7233) seven-two hours prior to any excavation to accurately establish the location of all underground utilities located on the project site.

(4) Where dimensions on the project drawings are unclear, contact the Project Engineer immediately for clarification.

(5) It is the General Contractor's responsibility to ensure that the Project drawings reflect the latest revisions.

JOB SITE SAFETY NOTES:

(1) PROVIDE ADEQUATE SAFETY FOR ALL WORKERS AND THE GENERAL PUBLIC ON AND NEAR THE JOB SITE AT ALL TIMES.

(2) FOLLOW THE SAFETY PROCEDURES SET FORTH BY THE VERMONT OCCUPATIONAL SAFETY AND HEALTH ADMINISTRATION, (VOSH) AT A MINIMUM, AT ALL TIMES.

(3) ALL EXCAVATION AND HOLES SHALL BE FILLED, COVERED OR BACKFILLED AT THE END OF EACH WORKING DAY.

(4) AT THE END OF EACH WORKDAY, ALL UNFINISHED WORK SHALL BE IDENTIFIED IN SUCH A MANNER SO AS TO WARN UNAUTHORIZED PERSONNEL FROM ENTERING OR USING THE UNFINISHED AREA.

REVISIONS

08/15/00 REVISED DRIVEWAY	G
09/20/00 REVISED ROAD ENTRANCE AND GRADING	G/B

CHAMPLAIN CONSULTING ENGINEERS
85 PRIM ROAD, P.O. BOX 453
COLCHESTER, VERMONT 05448
(802) 863-8000
(802) 864-1878 FAX



**ROSEN PROPERTY
PARTIAL SITE PLAN**

DRAWN: CCE
CHECKED: GJB
SCALE: AS NOTED
DATE: 05/25/00
JOB NO.: 99170
SHEET: C-1

STREET COMMISSION # 4
10 of 10

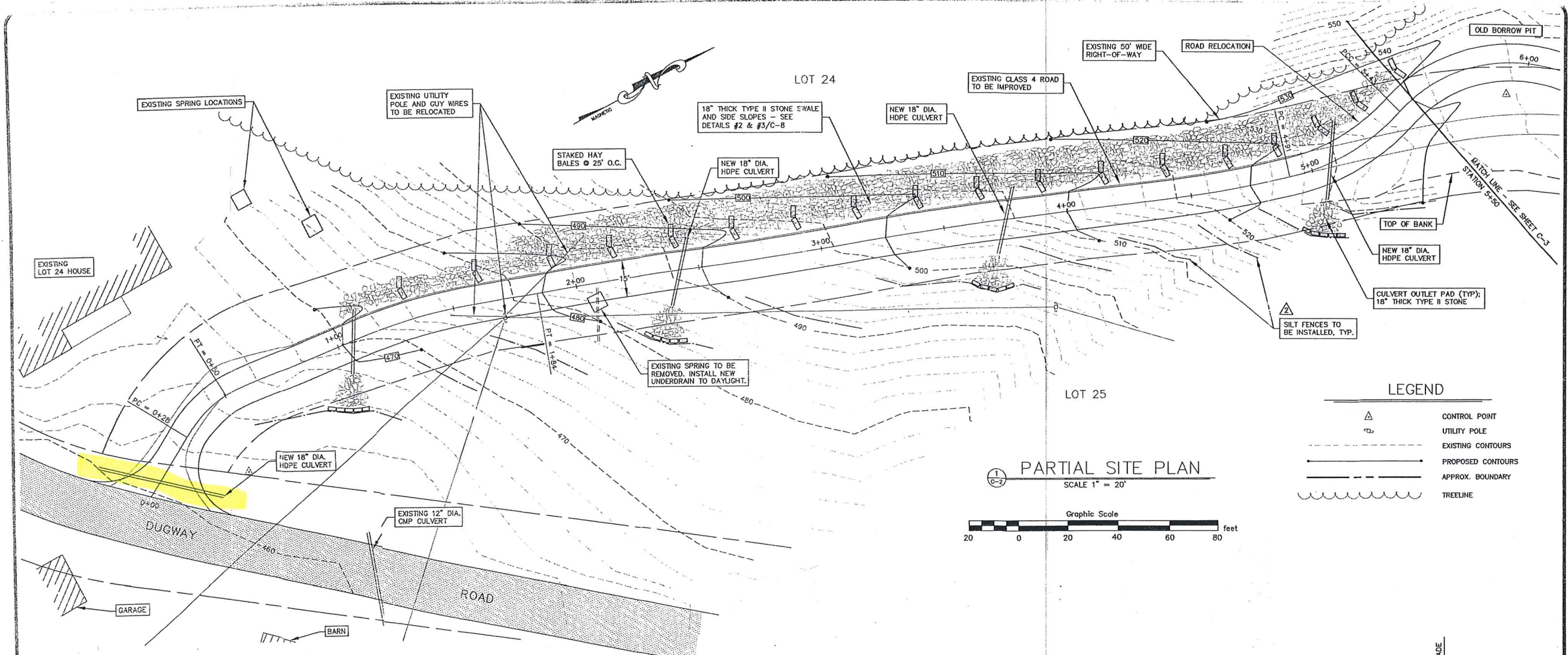

PARTIAL SITE PLAN
SCALE 1" = 20'

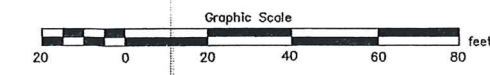

LEGEND

	CONTROL POINT
	UTILITY POLE
	EXISTING CONTOURS
	PROPOSED CONTOURS
	APPROX. BOUNDARY
	TREELINE

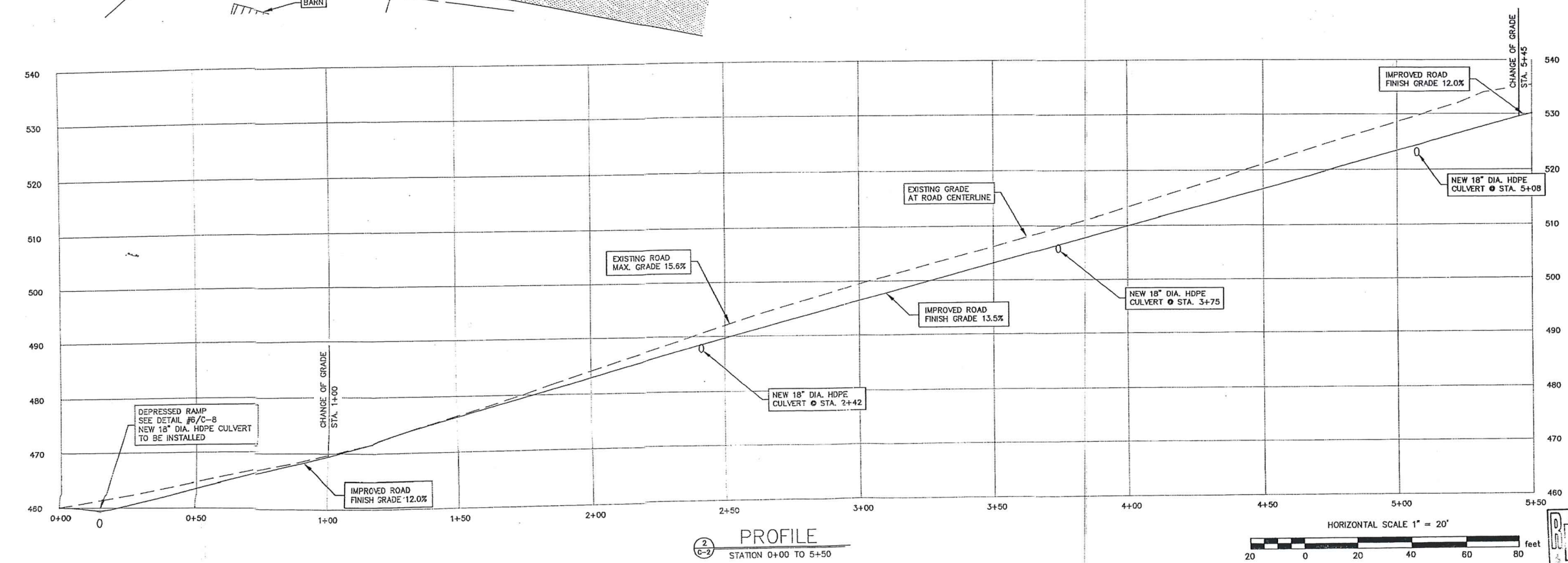

PROFILE
STATION 0+00 TO 5+50

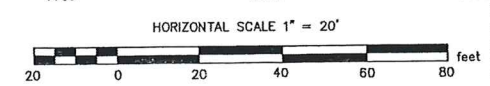

REVISIONS

9/20/00 REVISED ROAD ENTRANCE	
11/20/00 REVISED SILT FENCES	

COPYRIGHT © 2000
CHAMPLAIN CONSULTING ENGINEERS
ALL RIGHTS RESERVED

CHAMPLAIN CONSULTING ENGINEERS
85 PRIMA ROAD, P.O. BOX 453
COLCHESTER, VERMONT 05446
(802) 863-8000
(802) 864-1872 FAX

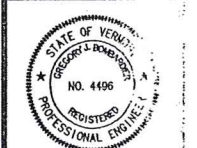

ROSEN PROPERTY
PLAN / PROFILE
DUGWAY ROAD
RICHMOND, VERMONT

DISTRICT APPLICATION EXHIBIT DATE: 05/25/00

DRAWN	CCE
CHECKED	CJB
SCALE	AS NOTED
DATE	05/25/00
JOB NO.	99170
SHEET	

C-2
OF 10 SHEETS

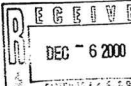

11-28117-10

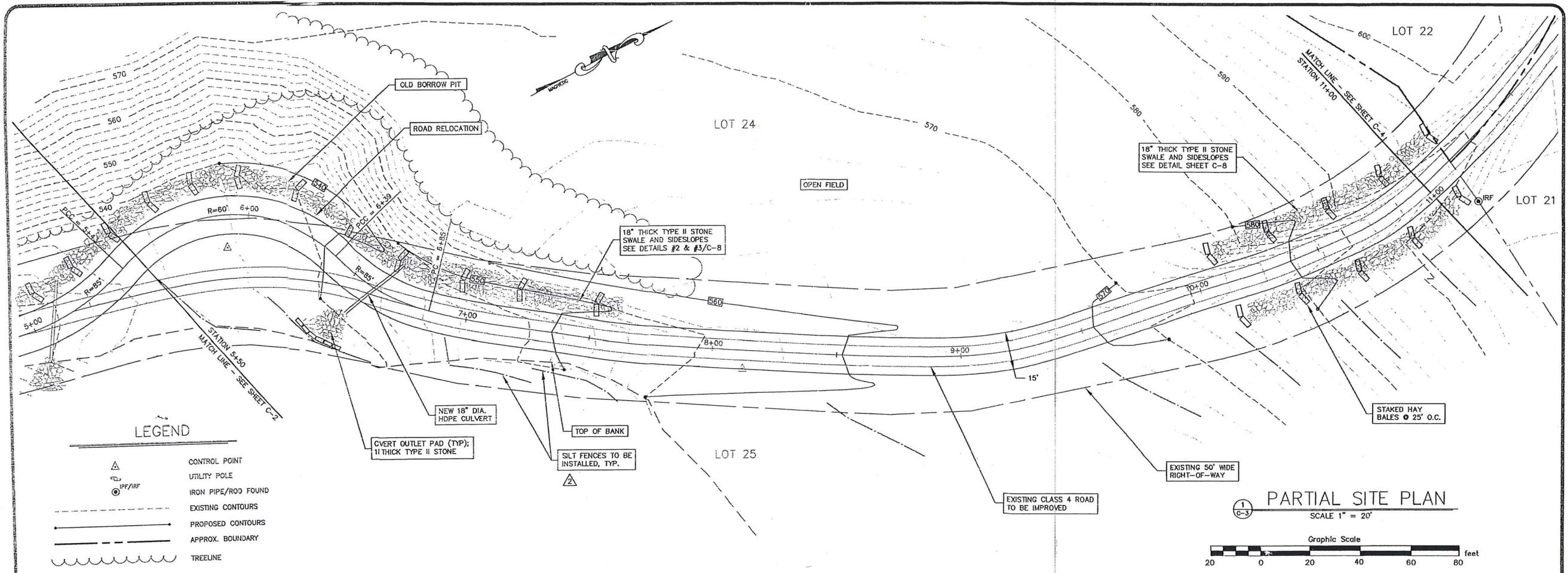

LEGEND

	CONTROL POINT
	UTILITY POLE
	IRON PIPE/ROD FOUND
	EXISTING CONTOURS
	PROPOSED CONTOURS
	APPROX. BOUNDARY
	TREELINE

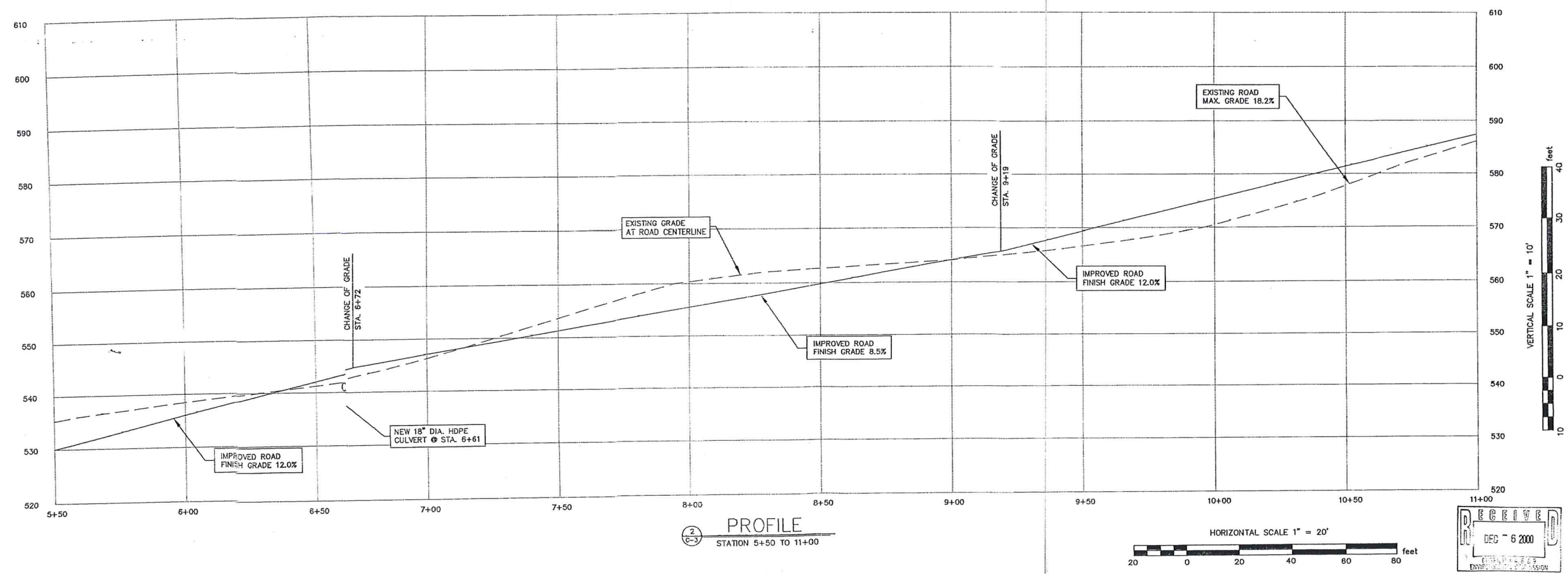
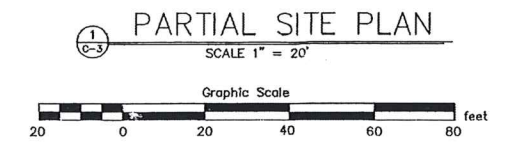

PROFILE
STATION 5+50 TO 11+00

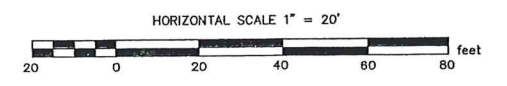

REVISIONS	BY
9/20/00 REVISED STATIONING	GJB
11/20/00 REVISED SILT FENCES	GJB

COPYRIGHT © 2000
CHAMPLAIN CONSULTING ENGINEERS
ALL RIGHTS RESERVED

CHAMPLAIN CONSULTING ENGINEERS
85 PRIM ROAD, P.O. BOX 453
COLCHESTER, VERMONT 05446
(802) 863-8080
(802) 364-1878 FAX

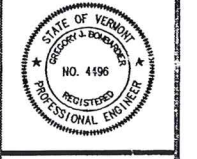

ROSEN PROPERTY
PLAN / PROFILE
BUGWAY ROAD
RICHMOND, VERMONT

DRAWN	CCE
CHECKED	GJB
SCALE	AS NOTED
DATE	05/25/00
JOB NO.	99170
SHEET	

C-3
OF 10 SHEETS

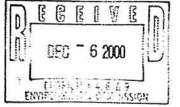

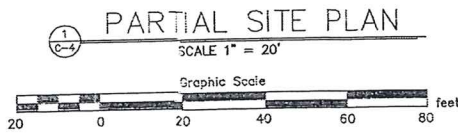
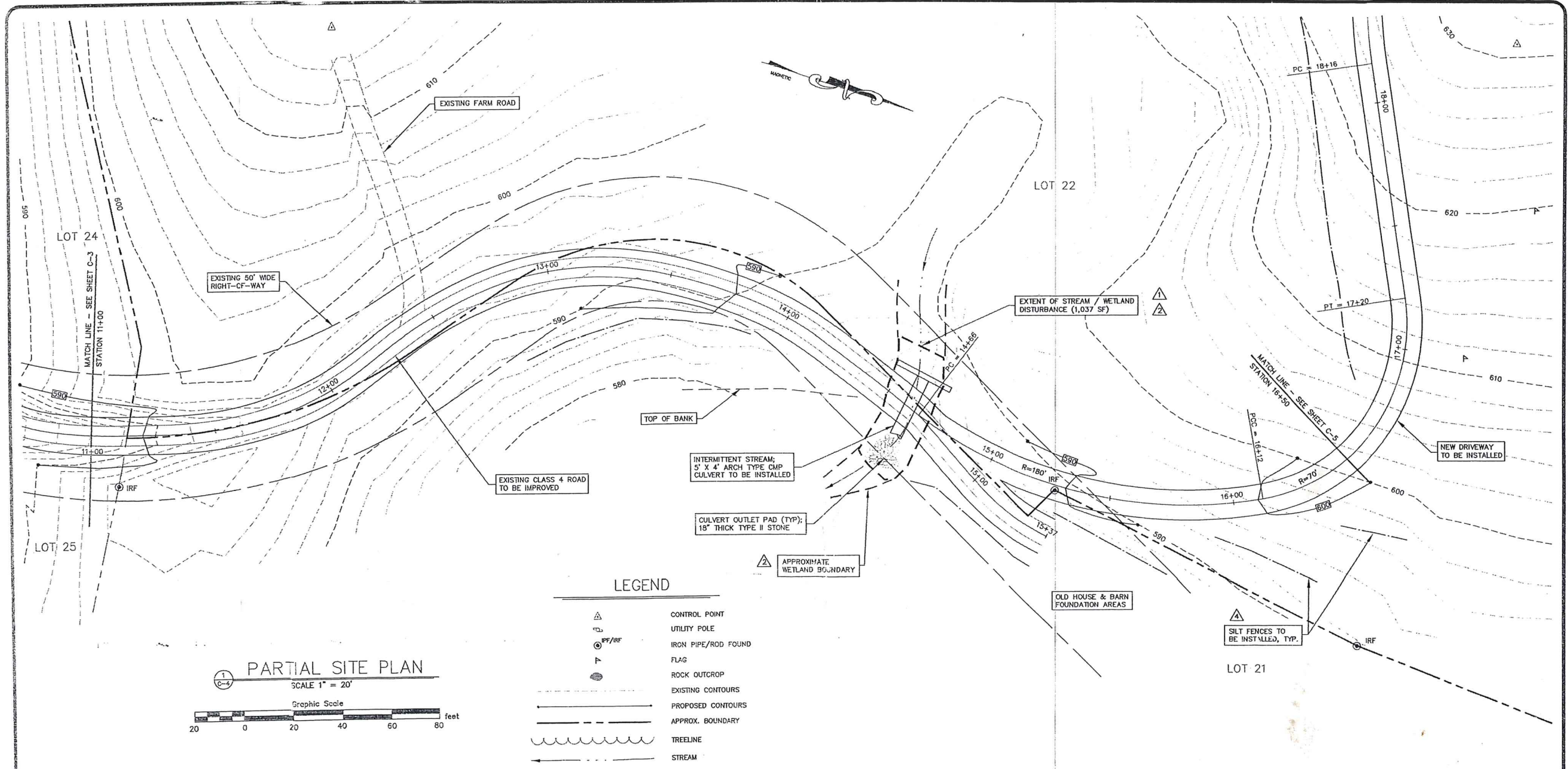

LEGEND

	CONTROL POINT
	UTILITY POLE
	IRON PIPE/ROD FOUND
	FLAG
	ROCK OUTCROP
	EXISTING CONTOURS
	PROPOSED CONTOURS
	APPROX. BOUNDARY
	TREELINE
	STREAM

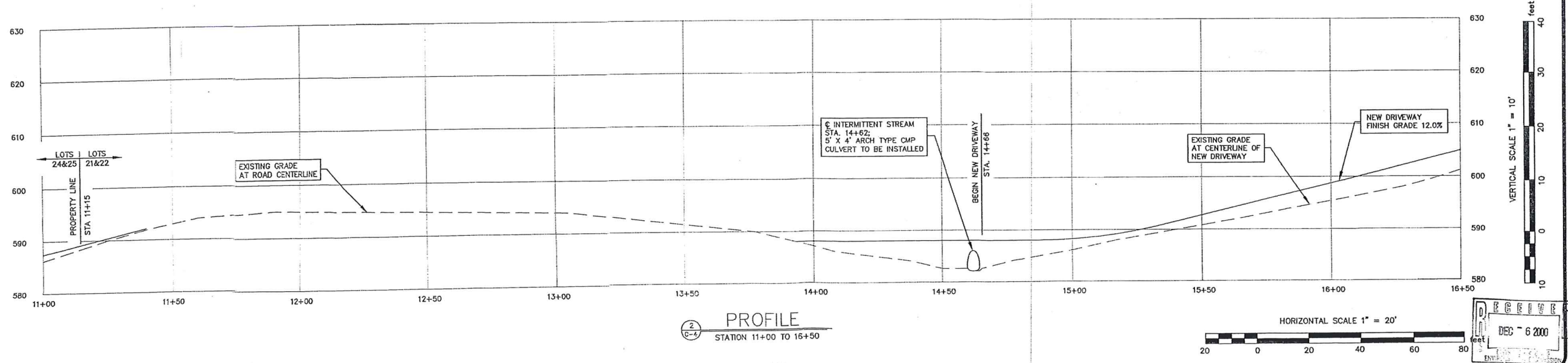

REVISIONS	BY
06/14/00 STREAM DISTURBANCE NOTE	GJB
07/21/00 WETLAND BOUNDARY NOTE	GJB
9/20/00 REVISED STATIONING	GJB
11/20/00 REVISED SILT FENCES	GJB

COPYRIGHT © 2000
CHAMPLAIN CONSULTING ENGINEERS
ALL RIGHTS RESERVED

CHAMPLAIN CONSULTING ENGINEERS
85 PRIM ROAD, P.O. BOX 453
COLCHESTER, VERMONT 05446
(802) 863-8060
(802) 864-1878 FAX



ROSEN PROPERTY
PLAN / PROFILE
DUGWAY ROAD
RICHMOND, VERMONT

DRAWN	CCE
CHECKED	GJB
SCALE	AS NOTED
DATE	05/25/00
JOB NO.	99170
SHEET	

C-4
OF 10 SHEETS

REVISIONS	BY
9/20/00 REVISED STATIONING	GJB
11/20/00 REVISED SILT FENCES	GJB

COPYRIGHT © 2000
CHAMPLAIN CONSULTING ENGINEERS
ALL RIGHTS RESERVED

CHAMPLAIN CONSULTING ENGINEERS
85 PRIM ROAD, P.O. BOX 453
COLCHESTER, VERMONT 05448
(802) 863-8060
(802) 864-1878 FAX

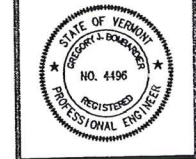

ROSEN PROPERTY
PLAN / PROFILE
DUGWAY ROAD
RICHMOND, VERMONT

DISTRICT ENGINEER: GREGORY J. BONNER
APPROVAL: [Signature]
DATE: 5/25/00

DRAWN: CCE
CHECKED: GJB
SCALE: AS NOTED
DATE: 05/25/00
JOB NO.: 99170
SHEET:

C-5
OF 10 SHEETS

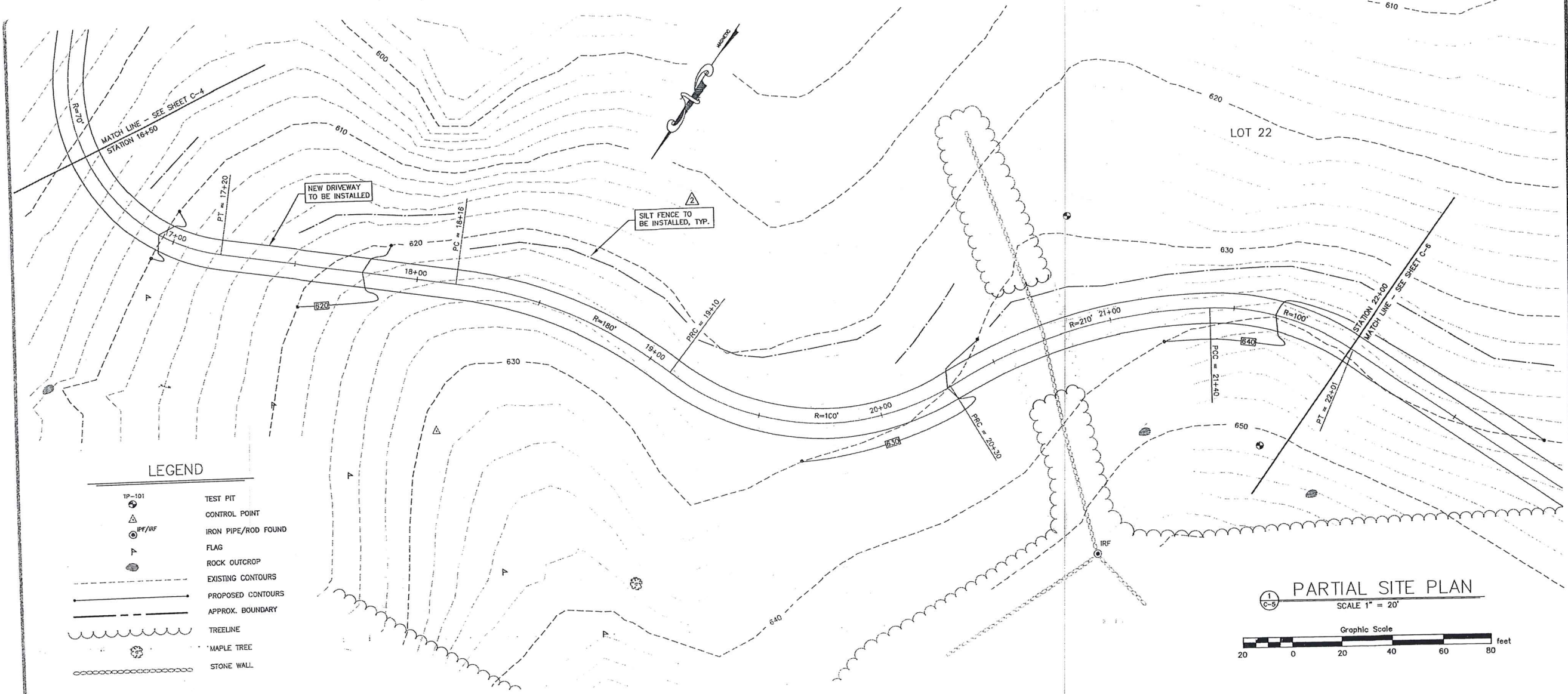

LEGEND

TP-101	TEST PIT
⊙	CONTROL POINT
△	IRON PIPE/ROD FOUND
▽	FLAG
⊠	ROCK OUTCROP
- - -	EXISTING CONTOURS
- - -	PROPOSED CONTOURS
- - -	APPROX. BOUNDARY
~~~~~	TREELINE
⊙	MAPLE TREE
=====	STONE WALL

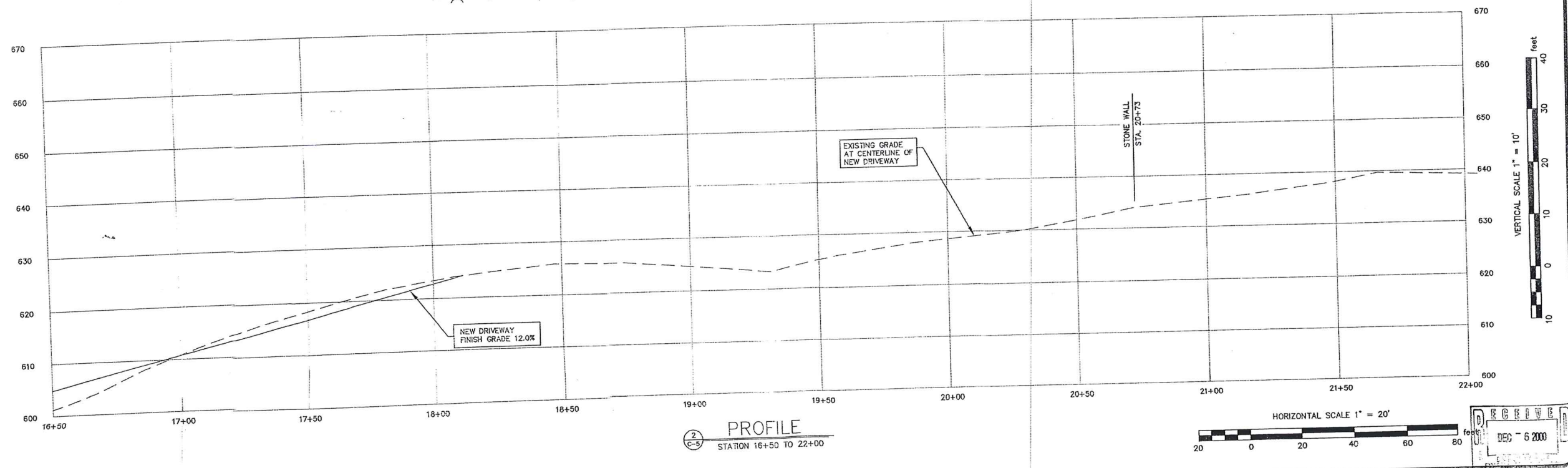

1. The C-5/99170/05/25/00/10-5560471/10/25/00/2005/11/21/00/25/00

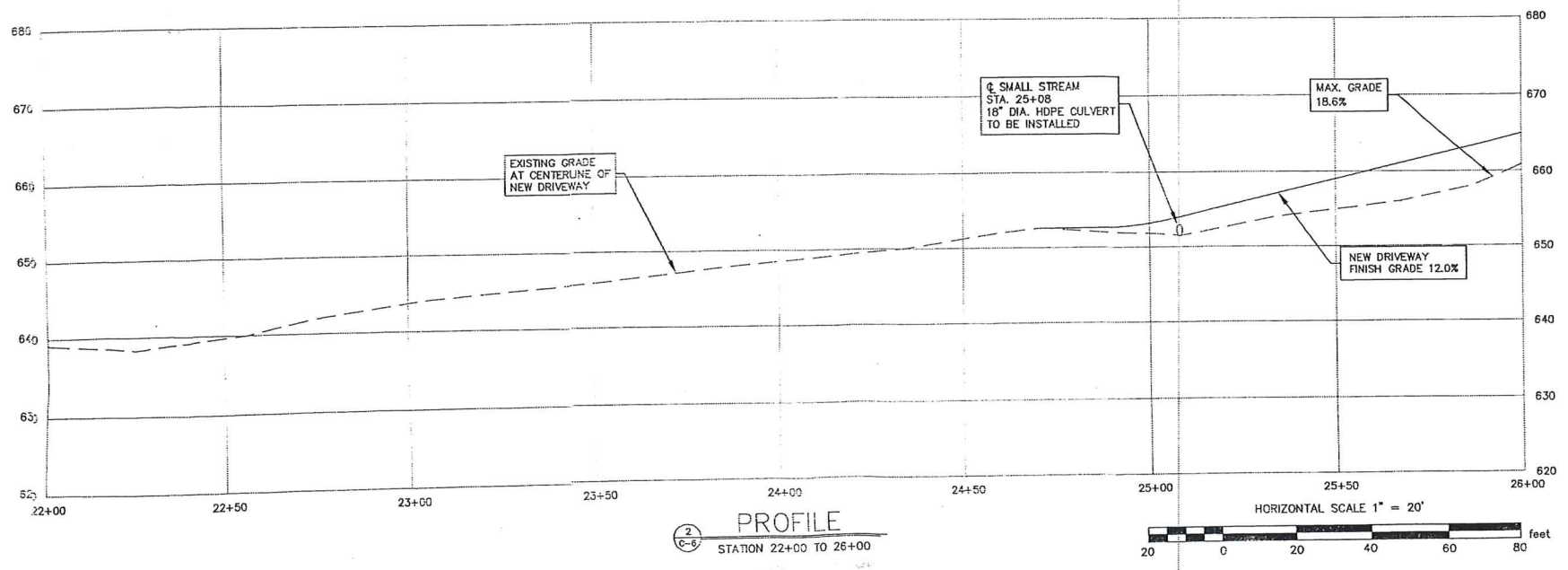
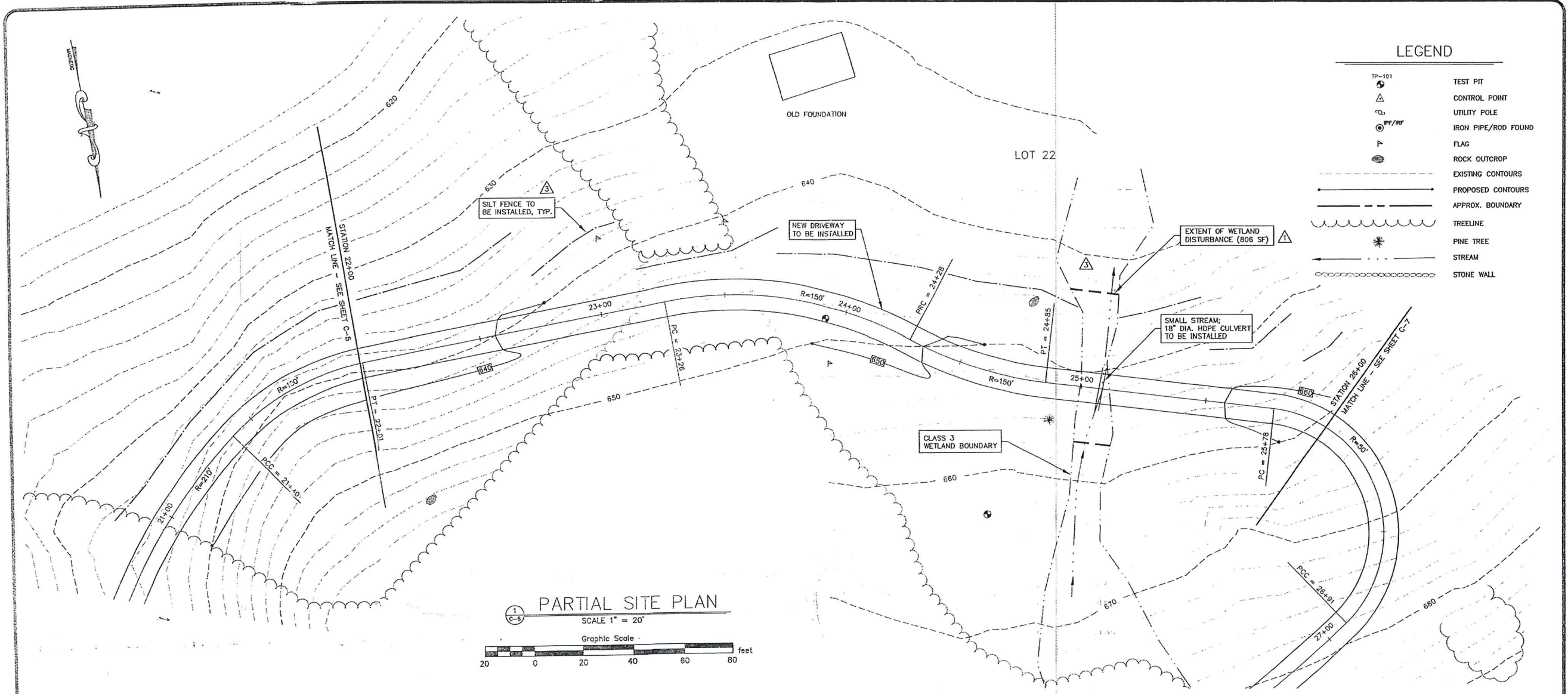

REVISIONS	BY
06/14/00 WETLAND DISTURBANCE NOTE	GJB
9/20/00 REVISED STATIONING	GJB
11/20/00 REVISED SILT FENCES AND REMOVED HAYBALES	GJB

COPYRIGHT © 2000  
CHAMPLAIN CONSULTING ENGINEERS  
ALL RIGHTS RESERVED

**CHAMPLAIN CONSULTING ENGINEERS**  
85 PRIM ROAD, P.O. BOX 453  
COLCHESTER, VERMONT 05446  
(802) 863-8060  
(802) 864-1878 FAX



**ROSEN PROPERTY**  
PLAN / PROFILE  
DUGWAY ROAD RICHMOND, VERMONT

DISTRICT APPLICATION NO. 99170  
DATE: 05/25/00

DRAWN	CCE
CHECKED	GJB
SCALE	AS NOTED
DATE	05/25/00
JOB NO.	99170
SHEET	

**C-6**  
OF 10 SHEETS

File: C:\proj\vermont\plan\rosen.dwg, Title: 7800, 11-21-00.mxd



APPROXIMATE LOCATION OF NEW DISPOSAL SYSTEM (BY OTHERS)

APPROXIMATE BUILDING ENVELOPE

**LEGEND**

- TP-101 TEST PIT
- △ CONTROL POINT
- UTILITY POLE
- ⊙ #F/#F IRON PIPE/ROD FOUND
- ▽ FLAG
- ⊙ ROCK OUTCROP
- - - EXISTING CONTOURS
- - - PROPOSED CONTOURS
- - - APPROX. BOUNDARY
- ~ TREELINE
- ⊙ PINE TREE
- STREAM
- ⊘ STONE WALL

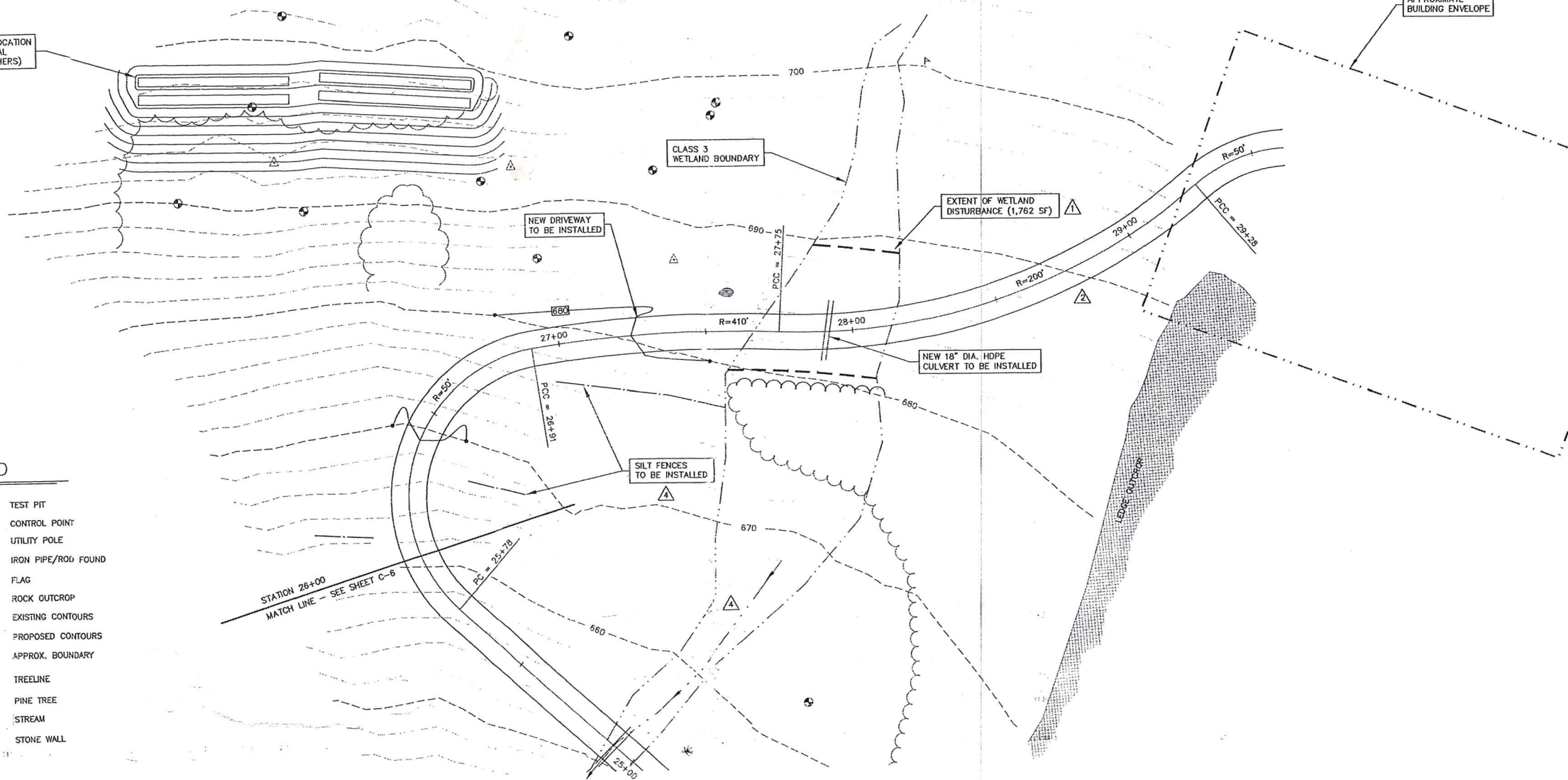

**PARTIAL SITE PLAN**

SCALE 1" = 20'

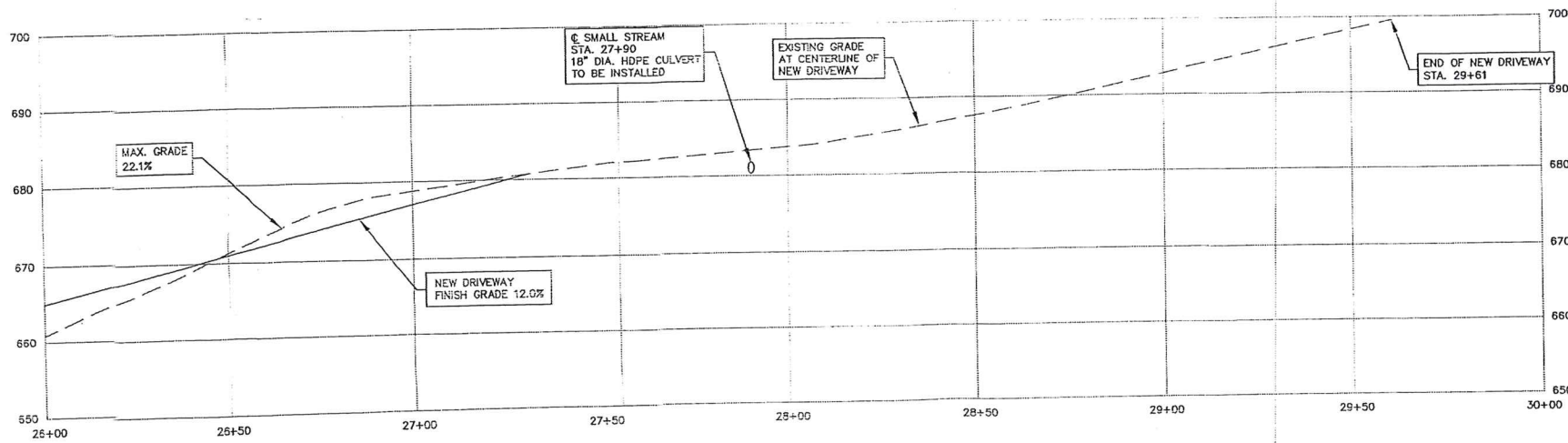
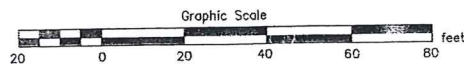

**PROFILE**

STATION 26+00 TO 30+00

HORIZONTAL SCALE 1" = 20'

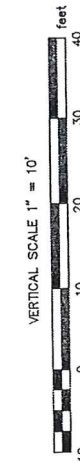

REVISIONS	BY
06/14/00 WETLAND DISTURBANCE NOTE	GJB
08/15/00 REVISED DRIVEWAY	GJB
09/20/00 REVISED STATIONING	GJB
11/20/00 REVISED SILT FENCES AND REMOVED HAY BALES	GJB

COPYRIGHT © 2000 CHAMPLAIN CONSULTING ENGINEERS ALL RIGHTS RESERVED

CHAMPLAIN CONSULTING ENGINEERS

85 PRIM ROAD, P.O. BOX 453  
COLCHESTER, VERMONT 05448  
(802) 865-8060  
(802) 864-1878 FAX



ROSEN PROPERTY  
PLAN / PROFILE

RICHMOND, VERMONT

DUGWAY ROAD

DRAWN	CCE
CHECKED	GJB
SCALE	AS NOTED
DATE	05/25/00
JOB NO.	99170
SHEET	

**C-7**

OF 10 SHEETS

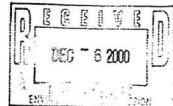

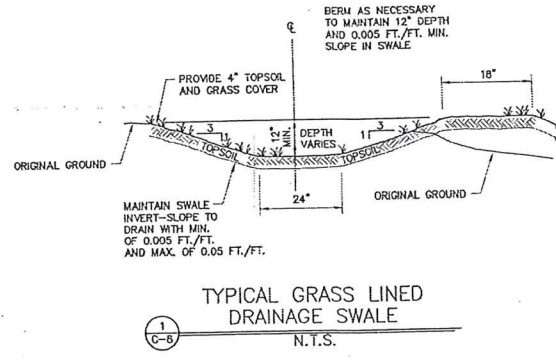

1  
C-B  
TYPICAL GRASS LINED DRAINAGE SWALE  
N.T.S.

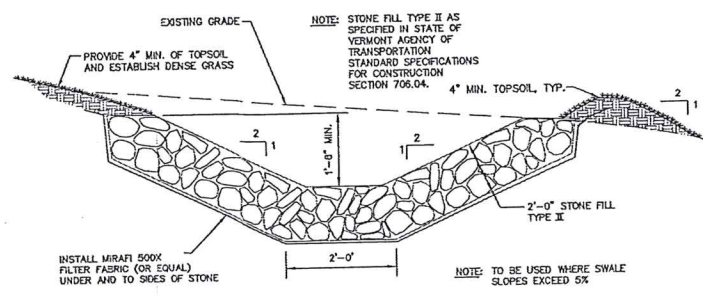

2  
C-B  
STONE LINED SWALE  
N.T.S.

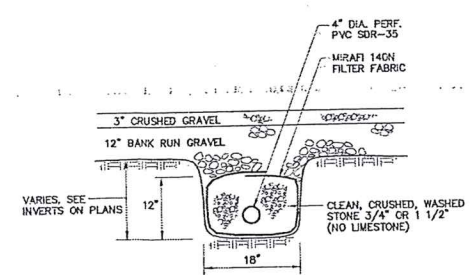

3  
C-B  
TYPICAL UNDERDRAIN DETAIL  
N.T.S.

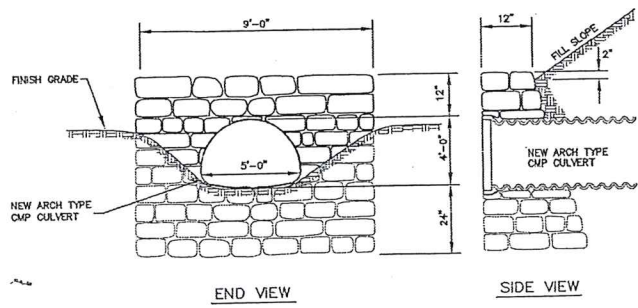

4  
C-B  
TYPICAL STONE HEADWALL DETAIL  
N.T.S.

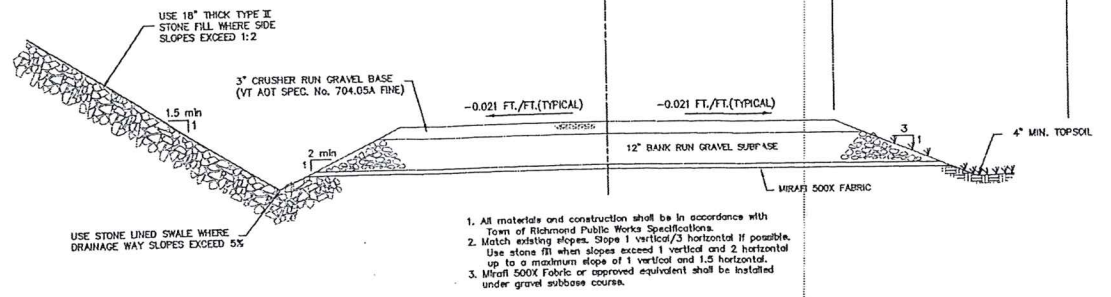

5  
C-B  
TYPICAL GRAVEL DRIVE CROSS SECTION  
N.T.S.

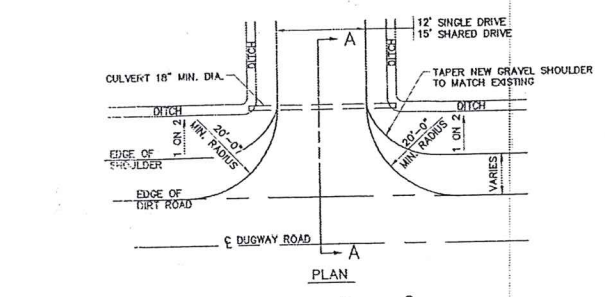

6  
C-B  
TYPICAL RURAL DRIVEWAY DETAIL  
N.T.S.

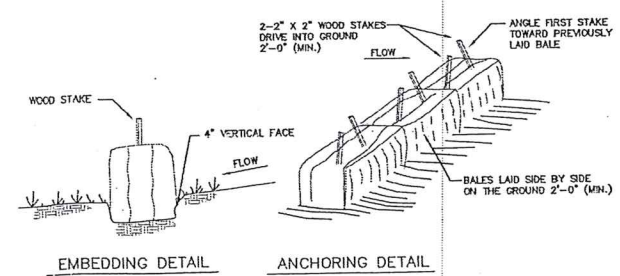

7  
C-B  
BALED HAY EROSION CHECKS  
N.T.S.

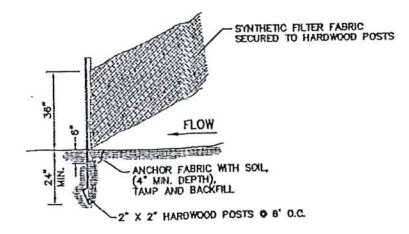

8  
C-B  
SILT FENCE DETAIL  
N.T.S.

SEEDING SPECIFICATION

URBAN MIX GRASS SEED		
WGT/FT	LIBS. LIVE SEED PER ACRE	TYPE OF SEED
37.5	45	CREeping RED FESCUE
31.25	37.5	KENTUCKY BLUEGRASS
31.25	37.5	WINTER HARDY, PERENNIAL RYE
100	100	# LIVE SEED/ACRE

CONSERVATION MIX GRASS SEED		
BY HEIGHT	LIBS. LIVE SEED PER ACRE	TYPE OF SEED
35	35	CREeping RED FESCUE
23	23	KENTUCKY BLUEGRASS
15	15	ANNUAL RYE
11	11	WINTER HARDY, PERENNIAL RYE (VARIETY PENNINE, MANHATTAN OR SIMILAR VARIETY)
6	6	WHITE CLOVER
10	10	HIGHLAND BENTGRASS
100	100	# LIVE SEED/ACRE

FERTILIZER - 20 LBS PER 1000 S.F.  
 SPRING SEEDING  
 FALL SEEDING

LIME - 60 LBS PER 1000 S.F.  
 DOLOMITE GROUND LIMESTONE  
 NOT LESS THAN 85% OF THE TOTAL CARBONATE

TOPSOIL  
 4" MINIMUM APPROVED TOPSOIL

STRAW MULCH - 2 BALES PER 1000 S.F.  
 APPLY BENDER OR NETTING AS NEEDED

MAINTENANCE, GUARANTEE AND ACCEPTANCE OF SEEDING  
 THE CONTRACTOR SHALL BE RESPONSIBLE FOR THE CARE AND MAINTENANCE, INCLUDING WATERING, OF SEEDING AREA UNTIL THE SEEDING IS INSPECTED AND ACCEPTED BY THE ENGINEER. INSPECTION SHALL BE MADE AFTER THE SECOND MOWING. THE CONTRACTOR SHALL NOTIFY THE ENGINEER 48 HOURS IN ADVANCE WHEN THE SECOND MOWING IS SCHEDULED.

RESEEDING SHALL BE DONE UNTIL ALL AREAS ARE COMPLETELY COVERED WITH A MATURE STAND OF GRASS. AN AREA SHALL BE CONSIDERED COVERED WHEN THE ENTIRE SURFACE CONTAINS A VIGOROUS STAND OF GRASS. AREAS THAT, IN THE OPINION OF THE ENGINEER, ARE PRECARIOUSLY WEEDY SHALL BE TILLED, FINE GRADED, FERTILIZED AND RESEEDED IN THE MANNER SPECIFIED ABOVE.

9  
C-B  
SITE RESTORATION  
N.T.S.

REVISIONS	BY
9/18/00 REVISED	GJB
DRIVEWAY X-SECTION AND NEW UNDERDRAIN DETAIL	

COPYRIGHT © 2000  
 CHAMPLAIN CONSULTING ENGINEERS  
 ALL RIGHTS RESERVED

CHAMPLAIN CONSULTING ENGINEERS  
 85 PRIM ROAD, P.O. BOX 453  
 COLCHESTER, VERMONT 05446  
 (802) 863-8060  
 (802) 864-1878 FAX

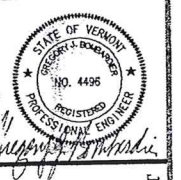

ROSEN PROPERTY  
 DETAILS  
 RICHMOND, VERMONT  
 DUGWAY ROAD

DRAWN	CCE
CHECKED	GJB
SCALE	AS NOTED
DATE	05/25/00
JOB NO.	99170
SHEET	

C-8

REVISIONS	BY
9/18/00 ALL X-SECTIONS REVISED	GJB

COPYRIGHT © 2000  
CHAMPLAIN CONSULTING ENGINEERS  
ALL RIGHTS RESERVED

**CHAMPLAIN CONSULTING ENGINEERS**  
85 PRIM ROAD, P.O. BOX 453  
COLCHESTER, VERMONT 05446  
(802) 863-8060  
(802) 864-1878 FAX



**ROSEN PROPERTY**  
SECTIONS

DUGWAY ROAD

RICHMOND, VERMONT

DRAWN  
CCE  
CHECKED  
GJB  
SCALE  
AS NOTED  
DATE  
05/25/00  
JOB NO.  
99170  
SHEET

**C-9**  
OF 10 SHEETS

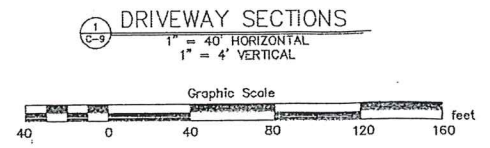
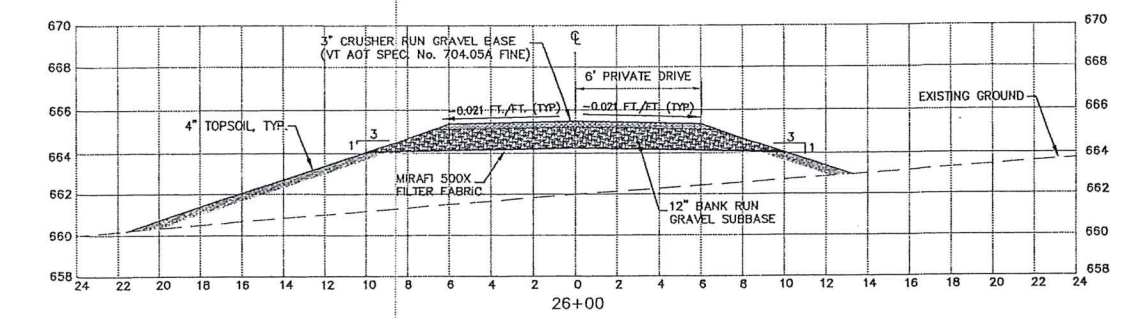
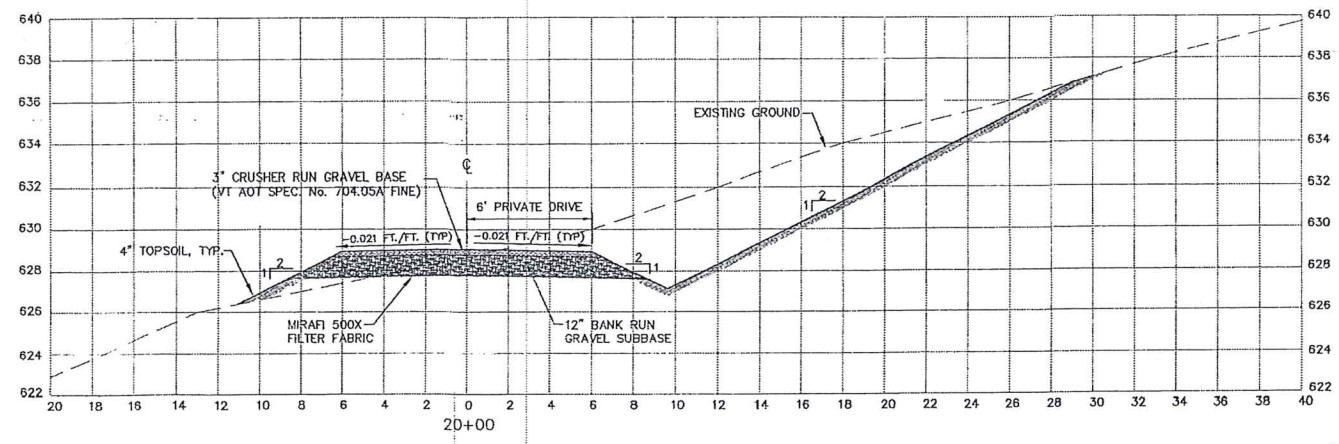
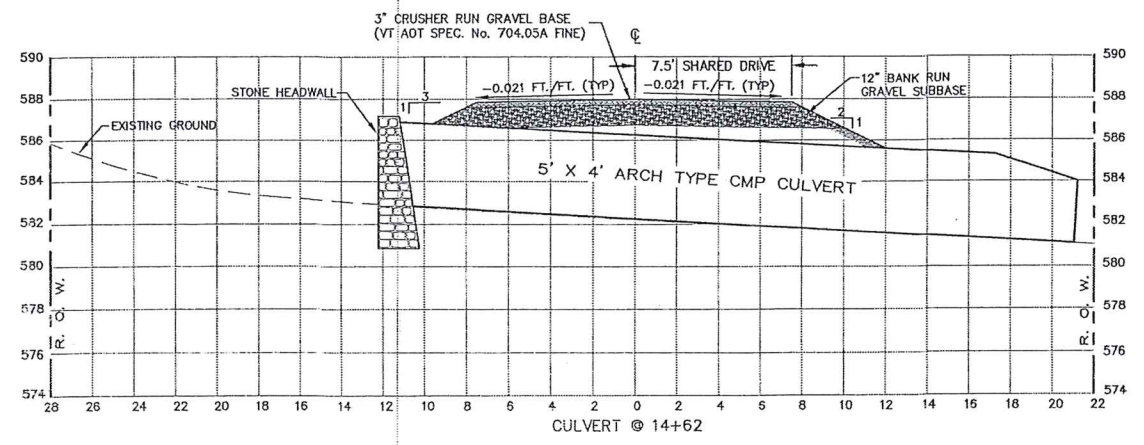
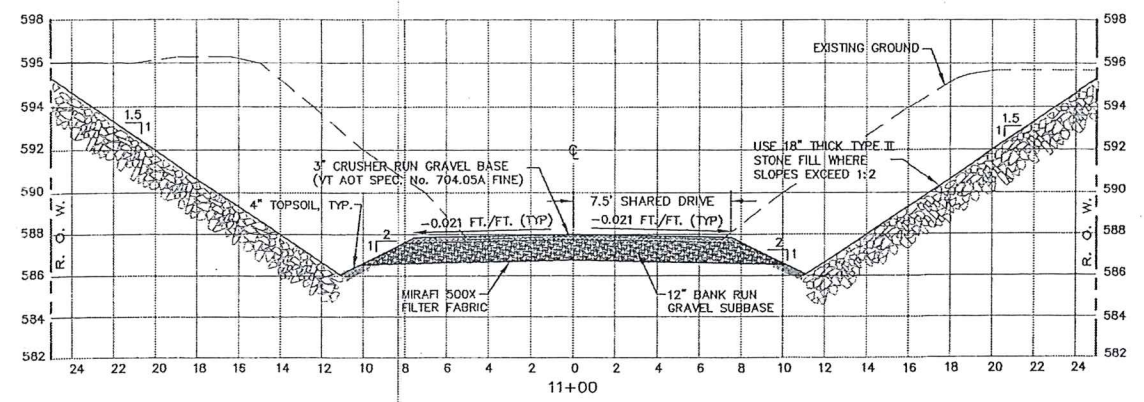
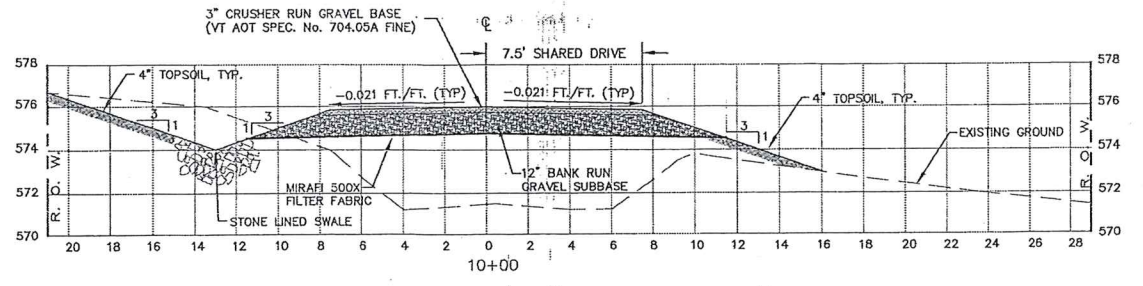
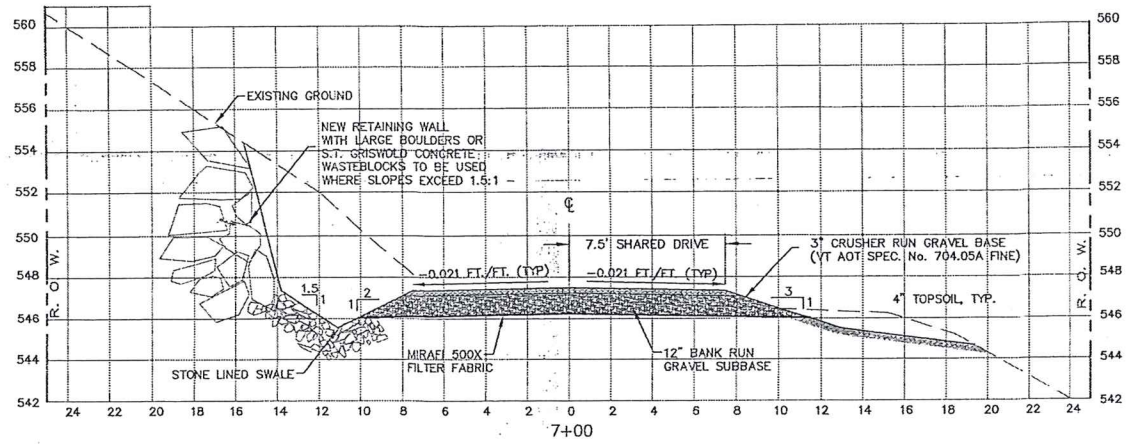
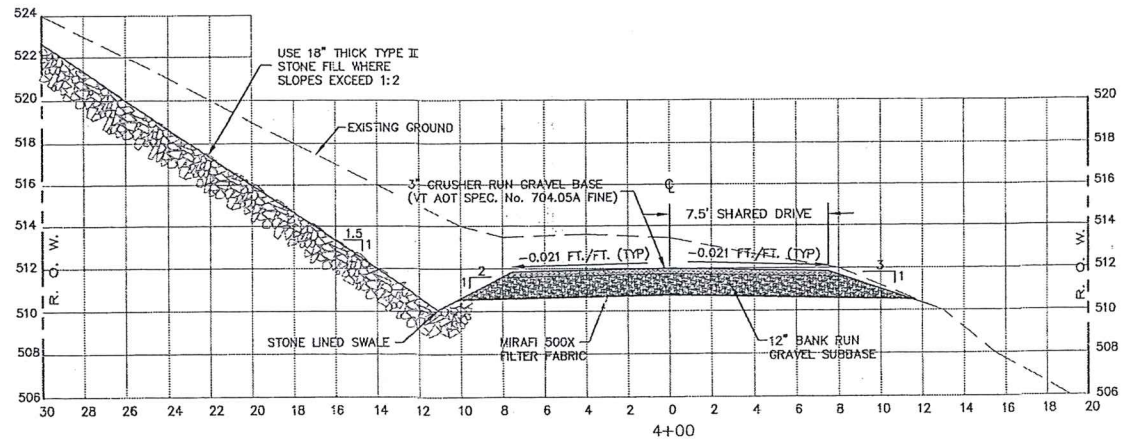
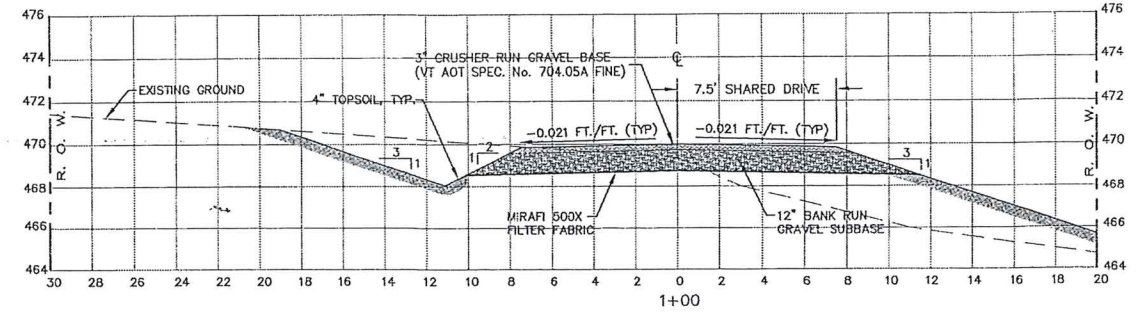

**GENERAL SPECIFICATIONS**

The Standard Specifications shall refer to the Vermont Agency of Transportation Standard Specifications for Construction (1990 Edition). All site work shall also be completed in accordance with the Town of Richmond's Public Works standards. Any discrepancies with the plans or specifications shall be reported to the Engineer prior to beginning that work.

**A. Earthwork**

1. The site shall be cleared of all debris and vegetation, and all topsoil shall be stripped prior to placing any fill material. Debris and vegetation shall be disposed of at an approved location.

2. The excavated material from an site shall not be used within five feet (5') of the building or under parking lots, roads or sidewalks. General imported fill material shall not be larger than two inches (2") or have more than 20% passing the No. 200 sieve. All excess excavated material shall be disposed of at an approved location.

**3. Grading**

a. Perform all rough grading, including excavation, formation of embankments, shaping, sloping, compaction, construction of ditches, disposal of surplus or unsuitable material, and any work necessary to prepare the subgrades of all roadways, walks and parking areas. Grading shall be brought to the bottom of the base course under paved or surfaced areas and to within a minimum of 24 inches of finished grade under side slopes and/or embankment areas to receive loam along roadways, walks or parking areas.

b. Accomplish all excavation and fit within the slope and grade lines as indicated on the Drawings unless otherwise authorized in writing by the Owner. Parking lots shall be graded to full cross section width at sub-grade before placing any type of sub-base or pavement except that partial width construction is permissible where necessary for the maintenance of traffic.

c. Do not use frozen material in the construction of embankments.

d. Place all embankment materials in horizontal layers of uniform thickness across the full width of embankment, except when it is impractical to construct full width of the embankment and partial width layers are authorized by the Owner. Do not allow or place stumps, trees, rubbish or other unsuitable material in embankments. Begin layers of embankment at the deepest part of the fill.

e. Areas of soft, yielding or otherwise unsuitable material that will not meet compaction requirements shall be removed, replaced with suitable material and properly compacted at no cost to the Owner.

f. Place embankments for paved or surface areas in horizontal layers of depths which will result in layers of compacted material not exceeding 8 inches. Compact each layer as specified before placing each new layer. Use effective spreading equipment on each layer to obtain uniform thickness prior to compacting. Each layer shall be kept crowned to shed water to the outside edges of embankment and continuous leveling and manipulating will be required to assure uniform density. Construction equipment shall be routed over the entire surface of each layer.

g. If, during the construction of the embankments, there is any indication that serious bulging, cracking, or unsafe movement may occur, the placing of fill shall be stopped or retarded to allow the material to stabilize.

h. All ditches and drains shall be constructed so they will effectively drain the roadway or parking lot before any sub-base or surface course material is placed. In handling materials, tools and equipment, the Contractor shall protect the subgrade from damage. In no case shall vehicles be allowed to travel in a single track and form ruts. If ruts are formed, the subgrade shall be reshaped and compacted and any pockets of clay, sand or soft material that may have been left in the subgrade shall be removed, replaced with approved material and properly compacted at the Contractor's expense. The subgrade shall be kept in such condition that it will drain. Sub-base, base or surface material shall not be deposited on the sub-grade until the sub-grade has been checked and approved by the Owner. After the sub-grade has been approved, hauling shall not be done nor equipment moved over the sub-grade which will distort the cross section. A tolerance of 1/2 inch above or below the finished sub-grade will be allowed provided that the 1/2 inch above or below sub-grade is not maintained for a distance longer than 50 feet, and that the required cross section is maintained.

**4. Compaction:**

a. General: Control soil compaction during construction providing minimum percentage of density specified for each area classification.

b. Percentage of Maximum Density Requirements: Compact soil to the percentages of maximum dry density for soils which exhibit a well defined moisture-density relationship determined in accordance with ASTM D 2049.

1. Loam or unpaired areas: Compact top 6" of sub-grade and each layer of backfill or fill material to 90% maximum dry density.

2. Compaction under paved and surfaced areas: The entire area of each layer shall be uniformly compacted to at least the required minimum density by use compact equipment consisting of rollers, compactors or a combination thereof. Earth-moving and other equipment not specifically manufactured for compaction purposes will not be considered as compaction equipment. Each layer for its full width shall be compacted to not less than 90 percent of the maximum dry density as determined by the Standard Method of Test for Moisture-Density Relations of Soils, ASTM-D698, Method C, except that the material in the top two feet of any embankment, immediately below the sub-grade shall be compacted to not less than 95 percent of the maximum dry density. The field density determination will be made by a qualified testing laboratory using a nuclear density gauge.

c. Moisture Control: Where sub-grades or layer of soil material must be moisture conditioned before compaction, uniformly apply water to surface of sub-grade, or layer of soil material, to prevent free water appearing on surface during or subsequent to compaction operations. Remove and replace or scarify and air dry soil material that is too wet to permit compaction to specified density.

**B. Improved Road and Drive**

1. The sub-grade shall be prepared in accordance with Section 203.12 of the Standard Specifications.

2. Bank run gravel (gravel for sub-base) shall meet the following grading requirements (Section 704.04):

Sieve Designation	Percentage by Weight Passing Square Mesh Sieves
No. 4	20 - 60
No. 100	0 - 12
No. 200	0 - 6

The gravel shall be uniformly graded from coarse to fine and the maximum size stone particles shall not exceed 2/3 of the thickness of the layer being placed. The gravel sub-base shall be compacted to 95% of the maximum dry density as determined by AASHTO-199.

3. Crushed Gravel for Sub-base: All materials shall be secured from approved sources. This gravel shall consist of angular and round fragments of hard durable rock of uniform quality throughout, reasonably free from thin elongated pieces, soft or disintegrated stone, dirt, organic or other objectionable matter. The grading requirements shall conform to the following table (Section 704.05 - Fine):

Sieve Designation	Percentage by Weight Passing Square Mesh Sieves
2"	100
1 1/2"	90 - 100
No. 4	30 - 60
No. 100	0 - 12
No. 200	0 - 6

The crushed gravel shall be compacted to 95% of the maximum dry density as determined by AASHTO-199.

4. Dense Graded Crushed Stone for Sub-base: Dense graded crushed stone for sub-base shall consist of clean, hard, uniformly graded, crushed stone. It shall be reasonably free from dirt, deleterious material and pieces which are structurally weak and shall meet the following requirements:

a. Source: This material shall be obtained from approved sources and the area from which this material is obtained shall be stripped and cleared before blasting.

b. Grading: This material shall meet the requirements of the following table:

Sieve Designation	Percentage by Weight Passing Square Mesh Sieves
3 1/2"	100
3"	90 - 100
2"	75 - 100
1 1/2"	50 - 80
1"	30 - 60
No. 4	15 - 40
No. 200	0 - 6

**EROSION CONTROL**

**1. General Notes**

a. The Contractor shall construct and maintain all erosion control measures in accordance with the Vermont Handbook for Soil Erosion and Sediment Control on Construction Sites, Special Publication no. 3.

**2. Construction Sequence**

a. The Contractor shall be responsible for establishing all erosion control measures delineated on the plans and any additional measures that are necessary to minimize erosion. The Contractor shall have erosion control materials and installation equipment on site at all times.

b. Silt fences shall be installed along the base of the fill slopes. This shall remain in place until the project site has been stabilized. Install hay bales in grass-lined swales 50 feet on center to prevent silt from washing into the drainage system during construction. Hay bales shall be removed when vegetation is established.

c. Control dust through the application of calcium chloride or water.

d. Excavated material from earth excavation and ditch digging shall be disposed of offsite or used for project fill material if determined suitable by the Owner's Representative.

e. All temporary erosion control measures required for any proposed winter work shall be installed prior to October 1. These measures shall be in place prior to the commencement of any site-work or earth-moving.

**3. Temporary Measures**

a. Hay Bale Check Dam and Inlet Protection - Bales shall be placed in a row with ends tightly abutting the adjacent bales. Each bale shall be imbedded in the soil a minimum of 4 inches. Bales shall be securely anchored in place by stakes driven through the bales. The first stake in each bale shall be driven toward the previously laid bales to force the bales together.

Bales shall be repaired or replaced as needed. Once vegetation is established and the bales are no longer needed for erosion control, they shall be removed. Sediment deposits shall then be removed and placed in an upland area where there is no danger of further erosion.

b. Silt Fences - The silt fences shall be constructed in accordance with the construction detail. The fence shall generally be placed 10 feet from the toe of the slope or as shown on the plan. The ends of the fence shall be placed uphill to form a horseshoe shape to trap all runoff.

The silt fences shall be inspected periodically for damage or build-up of sediment. All damaged fences shall be repaired or replaced. Sediment deposits shall be removed from the fence as they build up and be placed in an area where there is no danger of further erosion.

c. Erosion Matting - Erosion matting shall be placed on all grass-lined swales with profile grades exceeding 5.0% and shall be placed and maintained in accordance with the Vermont Agency of Transportation Standard Specifications Sections 654 and 755.07.

d. Dust Control - During construction, dust will be controlled with water distributed by a hand-mounted spray bar. At the direction of the Engineer, Calcium Chloride AASHTO M 144 or Sodium Chloride M 143 may be used.

e. All stockpile material (loam, borrow, etc.) will have a hay bale dike or silt fence constructed around the perimeter. Seed and mulch stockpile material as soon as possible to prevent soil erosion and sedimentation off site. Loose stockpiles on the uphill side of the disturbed area, if possible. During windy conditions, stockpiled material shall be covered or watered appropriately to prevent wind erosion.

f. Slopes greater than 1:3 shall have erosion control netting installed to stabilize the slope and reduce the erosion potential. Install netting over mulched slopes so that all parts are in contact with the soil and mulch. Pin netting with wire staples 3 feet o.c. to ensure full bonding with soil surface.

**4. Permanent Measures**

a. Grass Lined Swales - All swales that are not stone-lined shall be topsoiled, seeded, fertilized and mulched. Any area which shows signs of erosion shall be reseeded immediately and maintained until permanent vegetation is established.

b. Restoration - As soon as construction is completed in a given area, it shall be topsoiled, seeded, fertilized and mulched.

The topsoil shall be submitted to the Extension Service for analysis. Fertilizer shall be applied at approximately a rate of 400 pounds per acre depending on soil analysis. If necessary, lime shall be applied to the topsoil to produce a soil pH of approximately 6.0.

After the finished grade has been established and the fertilizer spread, plant the specific seed mixture and work firmly into the soil. Apply seed on the prepared seed bed with approved mechanical seeders or hydroseeding equipment. Upon completion of the above planting operations, roll all areas, leaving the surface of all areas true to grade, smooth, and free from hollows or other irregularities.

Thoroughly water all newly planted areas immediately after planting using a fine spray. Protect banks and mounds and prevent or reduce erosion that occurs. Banks, swales or other graded areas that have been washed out or have become damaged shall be repaired immediately, unless approval is granted by the Engineer to plant off season, seeding will be conducted only during the period from April 15th to October 15th. So as not to cause interference, no seeding is to proceed before other phases of the work have progressed sufficiently.

After seeding, mulch shall be applied at a rate of 2 tons per acre.

**5. Winter Construction**

a. If due to the project schedule, construction during the winter months is necessary, the contractor shall follow the winter construction procedures outlined in the "Vermont Handbook for Soil Erosion and Sediment Control on Construction Sites"

i. Minimize disturbance between October and May.

ii. All erosion control measures shall be in place prior to the ground freezing.

iii. Mulch shall be applied to all disturbed areas at a rate of 80 pounds per 1,000 square feet. The Contractor shall maintain all areas that are mulched until permanent vegetation can be established.

**6. Maintenance, Quarantee and Acceptance**

a. The Contractor shall be responsible for the care and maintenance including watering of seeded areas, until the seeding is inspected and accepted by the Owner.

b. Reseeding shall be done until all areas are completely covered with a mature stand of grass. An area shall be considered covered when the entire surface contains a verdurous stand of grass. Areas that, in the opinion of the Engineer, are predominantly weeds shall be plowed up, re-graded, fertilized and reseeded in the manner specified previously, exercising caution not to cause damage to new or existing plant material.

c. Maintain and guarantee all seeded area until acceptance.

REVISIONS	BY

COPYRIGHT © 2000  
CHAMPLAIN CONSULTING ENGINEERS  
ALL RIGHTS RESERVED

CHAMPLAIN CONSULTING ENGINEERS  
85 PRIM ROAD, P.O. BOX 453  
COLCHESTER, VERMONT 05446  
(802) 863-8080  
(802) 864-1878 FAX

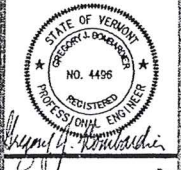

ROSEN PROPERTY SPECIFICATIONS  
RICHMOND, VERMONT  
DUGWAY ROAD

DRAWN	CCE
CHECKED	GJB
SCALE	
DATE	05/25/00
JOB NO.	99170
SHEET	

C-10  
OF 10 SHEETS