

Town Center Sign Replacement

Town of Richmond Select Board meeting 6/15/20

Summary of this presentation -

- Design for the new sign
- Budget for the project
 - Funding request from the town
- Timeline for project completion
- Status of project
 - BSA approval
 - Project permitting

Design -

- This design is based off of the aesthetic of the Round Church. This helps tie the heart of the community to the town's most historic and well known building.
- The design sheds water in order to avoid rot.
- The base color will be white with 3 inch lettering in black to allow for easy viewing from the street.
- The sign's posts will be sunk 3 ½ feet into the ground and stabilized with pea gravel to promote drainage.
- Simple landscaping will promote a neat and attractive appearance.

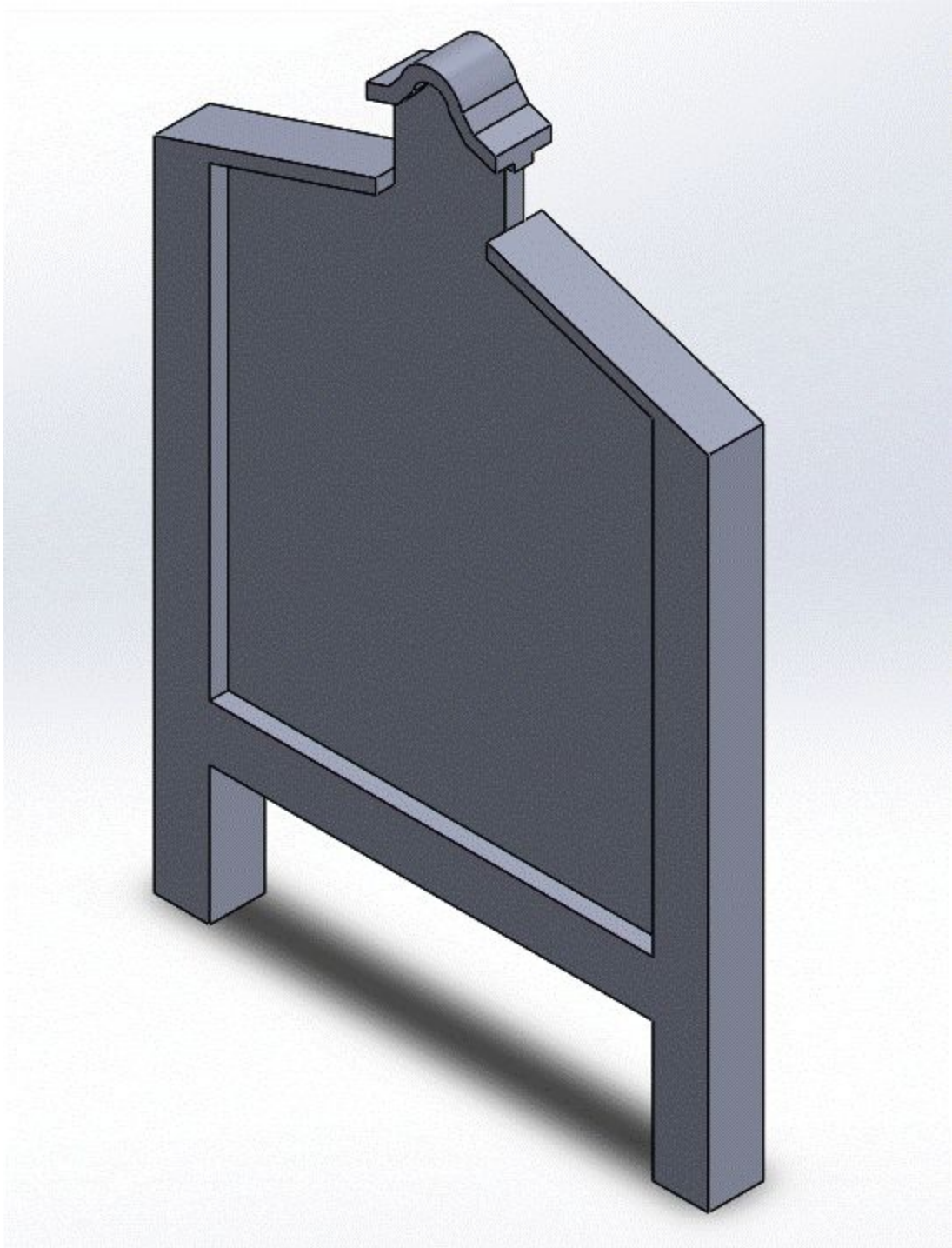

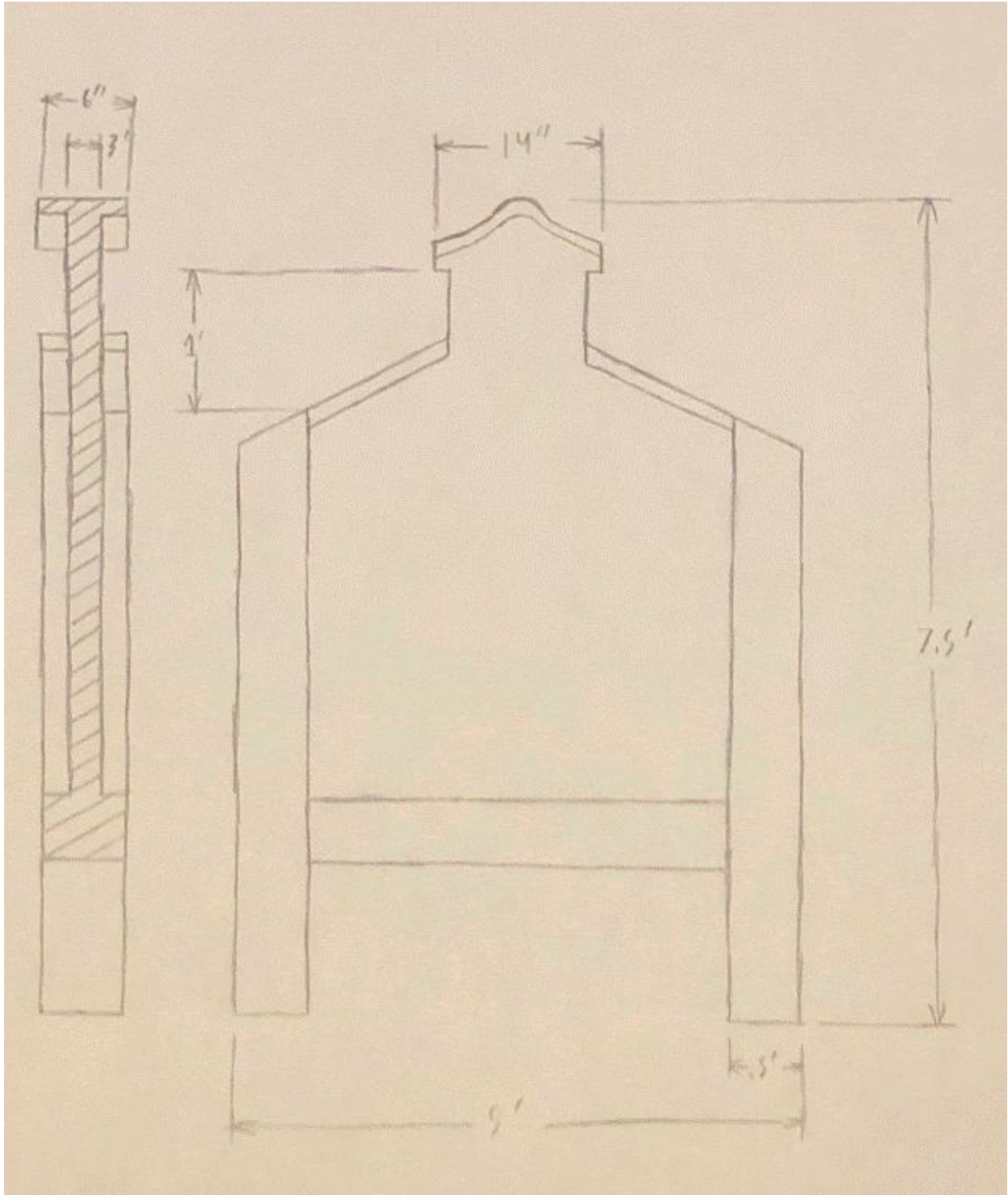

Note: These are the above ground measures. The buried posts are not depicted.

Project Budget -

Materials list:

- 2X: 3/4in x 4ft x 6ft - MDO plywood - \$47
- 3X: 6in x 6in x 8ft - White cedar - \$28
- Roofing Shingles - \$30
- Nails - \$12
- Stainless steel security screws - \$5
- 8X: 36in x 5in - Aluminum signs (company signs: Richmond Police, Town offices, etc.) - \$30
- Gravel - \$18
- 4X: 2 x 4 - \$4
- 1 gallon - Rustoleum latex - \$45
- Outdoor-rated silicone caulk - \$6
- Topsoil - \$5

The pricing estimate is derived from the Home Depot website as this was convenient for research purposes. Local businesses will be approached for material first .

Other:

- Auger rental - \$81
- Professional sign painting job estimate - \$200

Budget:

- Materials cost: \$650
 - Actual cost for materials is \$636 including all materials and Auger rental. Materials cost was rounded up to 650 to account for unforeseen cost.
- Total Project Cost: \$880
 - Total cost includes Materials cost plus \$230 which will be raised through fundraising and donation
 - The \$230 being raised is for painting

- Material may be donated for the project at a later point in time, These donations may lower the final cost. Any remaining town funds will be given back to the town

Funding Request from the Town of Richmond -

The objective of this project is to plan and carry out a project for the town using Scout volunteer hours, therefore there is no labor cost placed upon the town. I request that the town cover the funding for the materials cost (\$650). I will be raising the additional costs through fundraising and donations. If this fundraising is successful and raises more than the additional \$230 then the additional money will be used for material cost instead of the town's money. In which case the remaining town funding will be donated straight back to the town.

Project Timeline as of 6/9 -

- 6/15 - meeting with select board for update on project progression.
- Week of June 15th - Paperwork for the project will be turned into the Boy Scouts of America Green Mountain Council for approval.
- I hope to begin work and fundraising as soon as the project is approved.
- Work on the project will be carried out over a few weekends to accommodate schedules of the scouts, groups will also have to adhere to CDC and state guidelines regarding COVID-19.
- Removal of the current sign and its replacement will take two days. Due to the inexperience of the crew we will take time to make sure it is done properly. Note: Trained BSA adult volunteers and scout parents will be onsite to observe and ensure that work is performed safely.

Statue of Project -

- On the BSA side of things the project has been on hold until the budget is settled, once this is done I will collect the relevant information needed to submit to the council. Once I get their approval I can begin fundraising and work.
- Permit work for the project has been started. The permit application was dropped off at the Town Center on 6/4 and is presumably being processed

Thank you for your time